

# OPERATIVE

Pricelist 06/2025

REV.12 10-06

## MOVING

- 6 DRESSCHAIR
- 14 FORMA
- 20 GIADA
- 26 ATTIVA
- 32 CRONO
- 38 CRONO24
- 42 MOVING73Task
- 46 MOVING73Task Stool
- 50 ECOCHAIR
- 54 ECOCHAIR Visitor
- 60 DAMA
- 66 DAMA Visitor
- 70 FLEXA
- 74 FLEXA Visitor
- 78 R&G
- 82 OTAVO Q
- 86 OTAVO R
- 92 SLIM Task
- 93 SLIM Task Stool

# DRESSCHAIR

idea: *Pietro Lovato* & Walter Hösel



## 1. SCHIENALE:

Tubo sagomato d'acciaio, Ø 25mm, finitura cromata (15µm) rivestito in rete o imbottito con spugna e rivestito

## 2. SEDILE:

Polipropilene imbottito con spugna schiumata a freddo rivestito

## 3. MECCANISMO:

- SynchroPlus+, comando elevazione a gas, regolazione tensione schienale, inclinazione 20°sch. 8°sed. in 5 posizioni con antishock, traslazione sed. 6cm in 5 posizioni.
- SynchroTeK cromato o nero, comando elevazione a gas, regolazione tensione schienale: inclinazione 26°sch. 10.5°sed. in 5 posizioni con antishock, inclinazione negativa sed. 4,5° traslazione sed. 6cm in 5 posizioni

## 4. GAS:

Regolabile in altezza, rotazione, finitura cromata, molleggio

## 5. BASE:

- 5 razze in alluminio, Ø 710mm, finitura lucida
- 5 razze in ferro, Ø 710mm, finitura cromata (15µm)

## 6. RUOTE:

- Ø 65 mm, gommate o autofrenanti e gommate, finitura nera
- Ø 50 mm, autofrenanti o autofrenanti e gommate, finitura cromata
- Ø 65mm gommate forate

## 1. BACKREST :

Ø25mm shaped steel tube backrest, chromed finish (15µm), mesh upholstered or foam padded and upholstery

## 2. SEAT:

Polypropylene seat, cold injected foam padded, upholstery

## 3. MECHANISM:

- SynchroPlus+, gas lift height adj. Backrest tension adj. backrest inclination 20° in 5 locking position with antishock, seat inclination 8°. Sliding seat device 6cm in 5 positions
- Chromed or black SynchroTeK, gas lift height adj. Backrest tension adj. Backrest inclination: 26° in 5 positions with antishock; Seat inclination: 10.5°. Negative seat device 6cm in 5 positions

## 4. GAS LIFT:

Height adjustable, swivel, chromed finish, shock absorber springs

## 5. BASE:

- Polished aluminium 5 spoke base, Ø 710 mm
- Iron 5 spoke base, Ø 710 mm chromed finish (15µm)

## 6. CASTORS:

- Ø 65mm self-braking castors, or soft self-bracking. Black finish
- Ø 50 mm self-braking castors, or soft self-bracking. Chromed finish
- soft castors Ø 65mm with holes

## 1. DOSSIER:

Dossier en tube d'acier formé, Ø 25mm, finition chromé (15µm), revêtu en résille ou rembourré de mousse et tapissé

## 2. ASSISE:

Assise en polypropylène rembourrée de mousse moulée à froids, tapissée

## 3. MECANISME:

- SynchroPlus+, réglage en hauteur, réglage de tension, inclinaison dossier 20°et assise 8°, en 5 positions avec système anti-choc, profondeur d'assise 6 cm en 5 positions
- SynchroTeK chromé ou noir, réglage en hauteur, réglage de tension, inclinaison dossier 26°et assise 10,5°, en 5 positions avec système antichoc, inclinaison négative assise 4,5°, profondeur d'assise 6 cm en 5 positions

## 4. VERIN A GAZ:

Réglable en hauteur, pivotant, finition chromé, amortisseur

## 5. PIÈTEMENT:

- Piètement 5 branches alu poli, Ø 710mm
- Piètement 5 branches en métal, Ø 710mm, finition chromé (15µm)

## 6. ROULETTES:

- Ø 65mm, gommées ou autofreinantes et gommées, finition noir
- Ø 50mm, autofreinantes ou autofreinantes et gommées, finition chromé
- Roulettes creuses Ø 65mm gommées

## 1. RÜCKENLEHNE :

Geförmte Stahlrohr Rückenlehne, Ø 25mm, verchromt (15µm), Netzbespannt oder mit Schaumstoffkissen mit Überzug

## 2. SITZ:

Polypropylen Sitz, ausgepolstert mit kaltgeschäumten Polyurethan und Bezug

## 3. MECHANIK :

- SynchroPlus+, Gaslift Höhenv-erstellung, Rückenlehne mit Spannungsregler, 20°Rückenlehneneigung, 8°Sitzneigung, 5-stufige Einstellung mit Antishock, 6 cm Sitztiefenverstellung mit 5 Positionen
- SynchroTeK verchromt oder schwarz, Gaslift Höhenv-erstellung, Rückenlehne mit Spannungsregler, 26°Rückenlehneneigung, 10,5°Sitzneigung, negative Sitzneigung 4,5°, 5-stufige Einstellung mit Antishock, 6 cm Sitztiefenverstellung mit 5 Positionen

## 4. GASFEDER:

Sitzhöhenverstellung, drehbar, verchromt, mit Stoßdämpfende Feder

## 5. GESTELL :

- 5-Stern Alu poliertes Fußkreuz, Ø 710 mm
- 5-Stern Eisen Fußkreuz, Ø 710mm verchromt (15µm)

## 6. ROLLEN :

- Ø 65 mm gebremste, oder weiche gebremste Rollen, schwarz
- Ø 50 mm gebremste, oder weiche gebremste Rollen, verchromt
- Weiche rollen mit loch Ø 65mm

## 1. RESPALDO:

Tubo de acero conformado, Ø 25 mm, acabado cromado (15µm) cubierto de malla o acolchado con espuma y tapizado

## 2. ASIENTO:

Polipropileno acolchado con espuma de inyectado a frío, tapizado

## 3. MECANISMO:

- SynchroPlus+, control de elevación de gas, ajuste de tensión posterior, inclinación respaldo 20°. 8° asiento En 5 posiciones con antishock, desplazamiento asiento 6cm en 5 posiciones
- SynchroTeK cromado o negro, control de elevación de gas, ajuste de la tensión de respaldo: inclinación de 26° resp. 10.5° asiento. En 5 posiciones con antishock, inclinación negativa asiento. 4.5° desplazamiento asiento. 6cm en 5 posiciones

## 4. GAS:

Ajustable en altura, rotación, acabado cromado, muelle

## 5. BASE:

- 5 radios en aluminio, Ø 710mm, acabado brillante.
- 5 radios de hierro, Ø 710 mm, acabado cromado (15µm)

## 6. RUEDAS:

- Ø 65 mm, blandas o blandas con autofren, acabado negro
- Ø 50 mm, autofrenado o autofrenado y blandas, acabado cromado
- ruedas goma Ø 65 con huecos



# DRESSCHAIR

IMBOTTITA LISCIA O A FASCE, MOLLE SEDILE, TRAVERSO A "C"  
 UPHOLSTERED SMOOTH OR WITH STRIPES, PACKED SPRINGS, "C" SHAPED BAR  
 REMBOURRÉ SIMPLE OU EN BANDES, RESORTS ASSISE, TRAVERSE "C"  
 GEPOLSTERT MIT ODER OHNE STEPPUNGEN, FEDERKERN IM SITZ, TRAVERSE "C"  
 TAPIZADA LISA O EN BANDAS, MUELLAS ASIENTO, TRANVERSA "C"

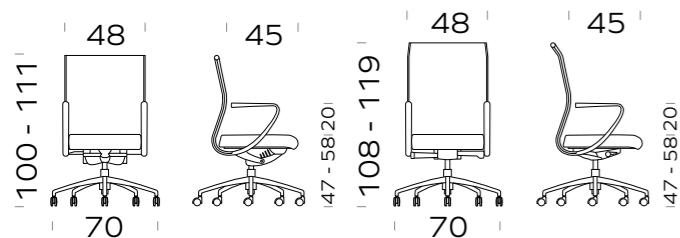

Mechanism: **SynchroPlus**  
 TECH INSIDE, SIMPLE OUTSIDE  
 Slidè

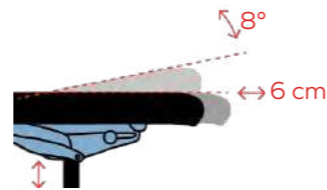

Blocco oscillante, Regolazione altezza/tensione, Regolazione in profondità del sedile  
 (Un-)locking device, Height/tension adjustment, Depth adjustment of the seat  
 Système de blocage-déblocage de l'oscillation, Réglage en hauteur/ d'intensité, Réglage en profondeur de l'assise  
 Blockierung der Rückenlehne /Spannungsregler / Höhenverstellung, Sitztiefenverstellung  
 Sistema de bloqueo-desbloqueo del respaldo, Ajuste de altura/tensión, Ajuste de profundidad del asiento

# DRESSCHAIR

IMBOTTITA LISCIA O A FASCE, MOLLE SEDILE, TRAVERSO A "C"  
 UPHOLSTERED SMOOTH OR WITH STRIPES, PACKED SPRINGS, "C" SHAPED BAR  
 REMBOURRÉ SIMPLE OU EN BANDES, RESORTS ASSISE, TRAVERSE "C"  
 GEPOLSTERT MIT ODER OHNE STEPPUNGEN, FEDERKERN IM SITZ, TRAVERSE "C"  
 TAPIZADA LISA O EN BANDAS, MUELLAS ASIENTO, TRANVERSA "C"

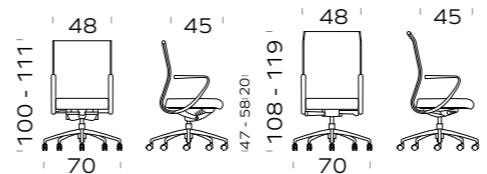

Mechanism: **SynchroTek**  
 Slidè Neg ↓

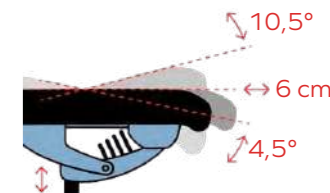

Blocco oscillante, Regolazione altezza/tensione, Regolazione in profondità del sedile, Inclinazione negativa  
 (Un-)locking device, Height/tension adjustment, Depth adjustment of the seat, Negative inclination  
 Système de blocage-déblocage de l'oscillation, Réglage en hauteur/ d'intensité, Réglage en profondeur de l'assise, Inclinaison négative  
 Blockierung der Rückenlehne /Spannungsregler / Höhenverstellung, Sitztiefenverstellung, Sitzneigungsverstellung  
 Sistema de bloqueo-desbloqueo del respaldo, Ajuste de altura/tensión, Ajuste de profundidad del asiento, Inclinación negativa

| BASE<br>BASE<br>PIETEMENT<br>GESTELL<br>BASE   | RUOTA/PIEDINO<br>CASTOR/FEET<br>ROULETTES/PATINS<br>ROLLEN/GLEITER<br>RUEDAS/PIES  | STRUTTURA<br>STRUCTURE<br>STRUCTURE<br>STRUKTUR<br>ESTRUCTURA  | SCHIENALE<br>BACKREST<br>DOSSIER<br>RÜCKENLEHNE<br>RESPALDO | VARIANTE<br>VARIANT<br>VARIANTE<br>VARIANTE<br>VARIANTE | CODICE<br>CODE<br>CODE<br>ARTIKEL<br>CÓDIGO | KG            | TESSUTI/FINITURE<br>UPHOLSTERIES/FINISHING<br>REVETEMENTS<br>STOFFGRUPPE<br>TAPICERÍAS |      |      |      |
|--|--|--|---|---|---|---------------|--|------|------|------|
|  |  |  |   |   |   |               | F  | G    | H    |      |
| <p>5 razze in alluminio<br/>5-spoke aluminium<br/>5 branches alu<br/>5-Stern Alu Fußkreuz<br/>estrella en aluminio</p>             | <p>d.65 gomme<br/>soft d.65 mm<br/>d.65mm gommées<br/>weiche D.65 mm<br/>ruedas goma diam.65</p>   | <p>Chromed</p>   | <p>Medium</p>   | SMOOTH  | <b>DR0075</b>                               | 17,30         | 1166   | 1518 | 1654 |      |
|  |  |  |   | WITH STRIPES  | <b>DR0117</b>                               | 17,30         | 1363   | 1733 | 2002 |      |
|  |  |  |   | SMOOTH  | <b>DR0063</b>                               | 17,40         | 1177   | 1531 | 1668 |      |
|  |  |  |   | WITH STRIPES  | <b>DR0099</b>                               | 17,40         | 1383   | 1760 | 2029 |      |
|  |  |  |   | SMOOTH  | <b>DR0156</b>                               | 17,30         | 1166   | 1518 | 1654 |      |
|  |  |  |   | WITH STRIPES  | <b>DR0157</b>                               | 17,30         | 1363   | 1733 | 2002 |      |
|  | <p>RAL 9005</p>  | <p>d.50mm autofrenanti gomme<br/>soft self-braking d.50mm<br/>d.50 mm gommées autofreinante<br/>weiche gebremste D.50 mm<br/>ruedas goma diam.50 autofreno</p> | <p>Chromed</p>  | <p>Medium</p>   | SMOOTH                                      | <b>DR0158</b> | 17,40  | 1177 | 1531 | 1668 |
|  |  |  |   |   | WITH STRIPES                                | <b>DR0159</b> | 17,40  | 1383 | 1760 | 2029 |
|  |  |  |   |   | SMOOTH                                      | <b>DR0021</b> | 18,90  | 1281 | 1633 | 1770 |
|  |  |  |   |   | WITH STRIPES                                | <b>DR0119</b> | 18,90  | 1478 | 1846 | 2116 |
|  |  |  |   |   | SMOOTH                                      | <b>DR0003</b> | 19,00  | 1291 | 1646 | 1783 |
|  |  |  |   |   | WITH STRIPES                                | <b>DR0101</b> | 19,00  | 1499 | 1875 | 2145 |
| <p>5 razze in ferro<br/>5-spoke iron<br/>5 branches en métal<br/>5-Stern es Eisen Fußkreuz<br/>estrella en metal</p>               | <p>d.50mm autofrenanti gomme<br/>soft self-braking d.50mm<br/>d.50 mm gommées autofreinante<br/>weiche gebremste D.50 mm<br/>ruedas goma diam.50 autofreno</p> | <p>RAL 9005</p>  | <p>Medium</p>   | SMOOTH  | <b>DR0160</b>                               | 18,90         | 1224   | 1576 | 1713 |      |
|  |  |  |   | WITH STRIPES  | <b>DR0161</b>                               | 18,90         | 1421   | 1789 | 2059 |      |
|  |  |  |   | SMOOTH  | <b>DR0162</b>                               | 19,00         | 1234   | 1589 | 1726 |      |
|  |  |  |   | WITH STRIPES  | <b>DR0163</b>                               | 19,00         | 1442   | 1818 | 2088 |      |
|  |  |  |   | SMOOTH  | <b>DR0187</b>                               | 16,60         | 1104   | 1456 | 1592 |      |
|  |  |  |   | WITH STRIPES  | <b>DR0188</b>                               | 16,60         | 1301   | 1671 | 1940 |      |
| <p>5 razze poliammide<br/>5-spoke polyamide<br/>5 branches polyamide<br/>5 - Stern Polyamid Fußkreuz<br/>estrella en polyamida</p> | <p>d.50mm autofrenanti gomme<br/>soft self-braking d.50mm<br/>d.50 mm gommées autofrein.<br/>weiche gebremste D.50 mm<br/>ruedas goma diam.50 autofreno</p>    | <p>RAL 9005</p>  | <p>Medium</p>   | SMOOTH  | <b>DR0189</b>                               | 16,70         | 1115   | 1469 | 1606 |      |
|  |  |  |   | WITH STRIPES  | <b>DR0190</b>                               | 16,70         | 1321   | 1698 | 1967 |      |
|  |  |  |   | SMOOTH  | <b>DR0191</b>                               | 16,60         | 1111   | 1463 | 1599 |      |
|  |  |  |   | WITH STRIPES  | <b>DR0192</b>                               | 16,60         | 1308   | 1678 | 1947 |      |
|  |  |  |   | SMOOTH  | <b>DR0193</b>                               | 16,70         | 1122   | 1476 | 1613 |      |
|  |  |  |   | WITH STRIPES  | <b>DR0194</b>                               | 16,70         | 1328   | 1705 | 1974 |      |

| BASE<br>BASE<br>PIETEMENT<br>GESTELL<br>BASE   | RUOTA/PIEDINO<br>CASTOR/FEET<br>ROULETTES/PATINS<br>ROLLEN/GLEITER<br>RUEDAS/PIES  | STRUTTURA<br>STRUCTURE<br>STRUCTURE<br>STRUKTUR<br>ESTRUCTURA  | SCHIENALE<br>BACKREST<br>DOSSIER<br>RÜCKENLEHNE<br>RESPALDO | VARIANTE<br>VARIANT<br>VARIANTE<br>VARIANTE<br>VARIANTE | CODICE<br>CODE<br>CODE<br>ARTIKEL<br>CÓDIGO | KG            | TESSUTI/FINITURE<br>UPHOLSTERIES/FINISHING<br>REVETEMENTS<br>STOFFGRUPPE<br>TAPICERÍAS |      |      |      |
|--|--|--|---|---|---|---------------|--|------|------|------|
|  |  |  |   |   |   |               | F  | G    | H    |      |
| <p>5 razze in alluminio<br/>5-spoke aluminium<br/>5 branches alu<br/>5-Stern Alu Fußkreuz<br/>estrella en aluminio</p> | <p>d.65 gomme<br/>soft d.65 mm<br/>d.65mm gommées<br/>weiche D.65 mm<br/>ruedas goma diam.65</p>   | <p>Chromed</p>   | <p>Medium</p>   | SMOOTH  | <b>DR0079</b>                               | 21,80         | 1427   | 1779 | 1916 |      |
|  |  |  |   | WITH STRIPES  | <b>DR0123</b>                               | 21,80         | 1624   | 1992 | 2262 |      |
|  |  |  |   | SMOOTH  | <b>DR0067</b>                               | 21,90         | 1437   | 1791 | 1928 |      |
|  |  |  |   | WITH STRIPES  | <b>DR0105</b>                               | 21,90         | 1644   | 2020 | 2289 |      |
|  |  |  |   | SMOOTH  | <b>DR0164</b>                               | 21,80         | 1427   | 1779 | 1916 |      |
|  |  |  |   | WITH STRIPES  | <b>DR0165</b>                               | 21,80         | 1624   | 1992 | 2262 |      |
|  | <p>5 razze in ferro<br/>5-spoke iron<br/>5 branches en métal<br/>5-Stern es Eisen Fußkreuz<br/>estrella en metal</p>   | <p>d.50mm autofrenanti gomme<br/>soft self-braking d.50mm<br/>d.50 mm gommées autofreinante<br/>weiche gebremste D.50 mm<br/>ruedas goma diam.50 autofreno</p> | <p>RAL 9005</p>   | <p>High</p>   | SMOOTH                                      | <b>DR0166</b> | 21,90  | 1437 | 1791 | 1928 |
|  |  |  |   |   | WITH STRIPES                                | <b>DR0167</b> | 21,90  | 1644 | 2020 | 2289 |
|  |  |  |   |   | SMOOTH                                      | <b>DR0027</b> | 23,40  | 1543 | 1894 | 2031 |
|  |  |  |   |   | WITH STRIPES                                | <b>DR0125</b> | 23,40  | 1739 | 2108 | 2377 |
|  |  |  |   |   | SMOOTH                                      | <b>DR0009</b> | 23,50  | 1552 | 1906 | 2043 |
|  |  |  |   |   | WITH STRIPES                                | <b>DR0107</b> | 23,50  | 1758 | 2133 | 2402 |
| <p>5 razze in ferro<br/>5-spoke iron<br/>5 branches en métal<br/>5-Stern es Eisen Fußkreuz<br/>estrella en metal</p>   | <p>d.50mm autofrenanti gomme<br/>soft self-braking d.50mm<br/>d.50 mm gommées autofreinante<br/>weiche gebremste D.50 mm<br/>ruedas goma diam.50 autofreno</p> | <p>RAL 9005</p>  | <p>Medium</p>   | SMOOTH  | <b>DR0168</b>                               | 23,40         | 1486   | 1837 | 1974 |      |
|  |  |  |   | WITH STRIPES  | <b>DR0169</b>                               | 23,40         | 1682   | 2051 | 2320 |      |
|  |  |  |   | SMOOTH  | <b>DR0170</b>                               | 23,50         | 1495   | 1849 | 1986 |      |
|  |  |  |   | WITH STRIPES  | <b>DR0171</b>                               | 23,50         | 1701   | 2076 | 2345 |      |

\* DISPONIBILE ANCHE IN  
 ALSO AVAILABLE  
 ÉGALEMENT DISPONIBLE EN  
 ERHÄLTICH AUCH IN  
 TAMBIÉN DISPONIBLE EN



RAL 9016



RAL 1012



RAL 3012



RAL 6021



RAL 7032



RAL 7046

\* DISPONIBILE ANCHE IN  
 ALSO AVAILABLE  
 ÉGALEMENT DISPONIBLE EN  
 ERHÄLTICH AUCH IN  
 TAMBIÉN DISPONIBLE EN



RAL 9016



RAL 1012



RAL 3012



RAL 6021



RAL 7032



RAL 7046

# DRESSCHAIR R

SCHIENALE IN RETE, MOLLE SEDILE, TRAVERSO A "C"  
 MESH BACKREST, PACKED SPRINGS, "C" SHAPED BAR  
 DOSSIER EN RÉSILLE, RESORTS ASSISE, TRAVERSE "C"  
 NETZ RÜCKENLEHNE, FEDERKERN IM SITZ, TRAVERSE "C"  
 RESPALDO EN MALLA, MUELLAS ASIENTO, TRANVERSA "C"

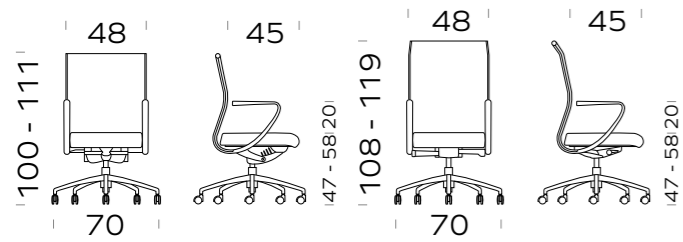

Mechanism: **SynchroPlus**  
 TECH INSIDE, SIMPLE OUTSIDE  
 Slidè

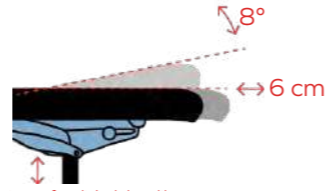

Blocco oscillante, Regolazione altezza/tensione, Regolazione in profondità del sedile  
 (Un-)locking device, Height/tension adjustment, Depth adjustment of the seat  
 Système de blocage-déblocage de l'oscillation, Réglage en hauteur/ d'intensité, Réglage en profondeur de l'assise  
 Blockierung der Rückenlehne /Spannungsregler / Höhenverstellung, Sitztiefenverstellung  
 Sistema de bloqueo-desbloqueo del respaldo, Ajuste de altura/tensión, Ajuste de profundidad del asiento

| BASE<br>BASE<br>PIETEMENT<br>GESTELL<br>BASE   | RUOTA/PIEDINO<br>CASTOR/FEET<br>ROULETTES/PATINS<br>ROLLEN/GLEITER<br>RUEDAS/PIES   | STRUTTURA<br>STRUCTURE<br>STRUCTURE<br>STRUKTUR<br>ESTRUCTURA | SCHIENALE<br>BACKREST<br>DOSSIER<br>RÜCKENLEHNE<br>RESPALDO | RETE<br>MESH<br>MAILLE<br>NETZ<br>MALLA | CODICE<br>CODE<br>ARTIKEL<br>CÓDIGO | KG            | TESSUTI/FINITURE<br>UPHOLSTERIES/FINISHING<br>REVETEMENTS<br>STOFFGRUPPE<br>TAPICERÍAS |      |      |      |      |
|--|---|---|---|---|-------------------------------------|---------------|--|------|------|------|------|
|  |   |   |   |   |                                     |               | D  | E    | F    | G    |      |
| <br>5 razze in alluminio<br>5-spoke aluminium<br>5 branches alu<br>5-Stern Alu Fußkreuz<br>estrella en aluminio  | <br>d.65 gommate<br>soft d.65 mm<br>d.65mm gommées<br>weiche d.65 mm<br>ruedas goma diam.65   |   | Medium  | M-L                                     | <b>DR0093</b>                       | 17,30         | 1041   | 1042 | 1046 | 1078 |      |
|  |   |   |   | M-L                                     | <b>DR0081</b>                       | 17,40         | 1047   | 1053 | 1059 | 1094 |      |
|  |   |   | RAL 9005  | High                                    | M-L                                 | <b>DR0172</b> | 17,30  | 1041 | 1042 | 1046 | 1078 |
|  |   |   |   |   | M-L                                 | <b>DR0173</b> | 17,40  | 1047 | 1053 | 1059 | 1094 |
| <br>5 razze in ferro<br>5-spoke iron<br>5 branches en métal<br>5-Stern es Eisen Fußkreuz<br>estrella en metal  | <br>d.50mm autofrenanti gommate<br>soft self-braking d.50mm<br>d.50 mm gommées autofreinante<br>weiche gebremste D.50 mm<br>ruedas goma diam.50 autofreno |   | Medium  | M-L                                     | <b>DR0052</b>                       | 18,80         | 1166   | 1173 | 1177 | 1209 |      |
|  |   |   |   | M-L                                     | <b>DR0034</b>                       | 19,00         | 1178   | 1183 | 1188 | 1225 |      |
|  |   |   | RAL 9005  | High                                    | M-L                                 | <b>DR0174</b> | 18,80  | 1109 | 1116 | 1120 | 1152 |
|  |   |   |   |   | M-L                                 | <b>DR0175</b> | 19,00  | 1121 | 1126 | 1131 | 1168 |
| <br>5 razze poliammide<br>5-spoke polyamide<br>5 branches polyamide<br>5 - Stern Polyamid Fußkreuz<br>estrella en polyamida                            | <br>d.50mm autofrenanti gommate<br>soft self-braking d.50mm<br>d.50 mm gommées autofrein<br>weiche gebremste D.50 mm<br>ruedas goma diam.50 autofreno     |   | Medium  | M-L                                     | <b>DR0195</b>                       | 16,60         | 979  | 980  | 984  | 1016 |      |
|  |   |   |   | M-L                                     | <b>DR0197</b>                       | 16,70         | 985  | 991  | 997  | 1032 |      |
| <br>design poliammide<br>5-spoke polyamide design<br>design 5 branches polyamide<br>5 - Stern Polyamid Design Fußkreuz<br>design estrella en polyamida | <br>d.50mm autofrenanti gommate<br>soft self-braking d.50mm<br>d.50 mm gommées autofrein<br>weiche gebremste D.50 mm<br>ruedas goma diam.50 autofreno     |   | High  | M-L                                     | <b>DR0198</b>                       | 16,60         | 986  | 987  | 991  | 1023 |      |
|  |   |   |   | M-L                                     | <b>DR0196</b>                       | 16,70         | 992  | 998  | 1004 | 1039 |      |

\* DISPONIBILE ANCHE IN  
 ALSO AVAILABLE  
 ÉGALEMENT DISPONIBLE EN  
 ERHÄLTlich AUCH IN  
 TAMBIÉN DISPONIBLE EN



# DRESSCHAIR R

SCHIENALE IN RETE, MOLLE SEDILE, TRAVERSO A "C"  
 MESH BACKREST, PACKED SPRINGS, "C" SHAPED BAR  
 DOSSIER EN RÉSILLE, RESORTS ASSISE, TRAVERSE "C"  
 NETZ RÜCKENLEHNE, FEDERKERN IM SITZ, TRAVERSE "C"  
 RESPALDO EN MALLA, MUELLAS ASIENTO, TRANVERSA "C"

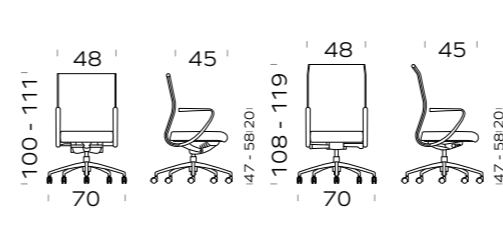

Mechanism: **SynchroTek**  
 Slidè Neg

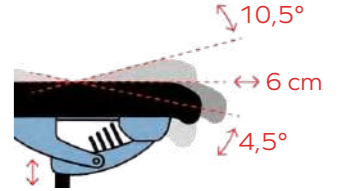

Blocco oscillante, Regolazione altezza/tensione, Regolazione in profondità del sedile, Inclinazione negativa  
 (Un-)locking device, Height/tension adjustment, Depth adjustment of the seat, Negative inclination  
 Système de blocage-déblocage de l'oscillation, Réglage en hauteur/ d'intensité, Réglage en profondeur de l'assise, Inclinasion négative  
 Blockierung der Rückenlehne /Spannungsregler / Höhenverstellung, Sitztiefenverstellung, Sitzneigungsverstellung  
 Sistema de bloqueo-desbloqueo del respaldo, Ajuste de altura/tensión, Ajuste de profundidad del asiento, Inclinación negativa





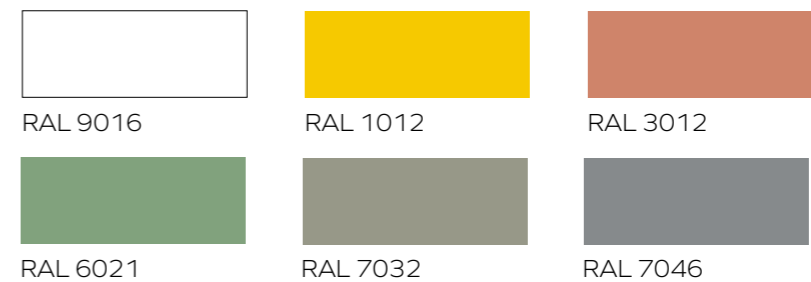



| BASE<br>BASE<br>PIETEMENT<br>GESTELL<br>BASE  | RUOTA/PIEDINO<br>CASTOR/FEET<br>ROULETTES/PATINS<br>ROLLEN/GLEITER<br>RUEDAS/PIES   | STRUTTURA<br>STRUCTURE<br>STRUCTURE<br>STRUKTUR<br>ESTRUCTURA | SCHIENALE<br>BACKREST<br>DOSSIER<br>RÜCKENLEHNE<br>RESPALDO | RETE<br>MESH<br>MAILLE<br>NETZ<br>MALLA | CODICE<br>CODE<br>ARTIKEL<br>CÓDIGO | KG            | TESSUTI/FINITURE<br>UPHOLSTERIES/FINISHING<br>REVETEMENTS<br>STOFFGRUPPE<br>TAPICERÍAS |      |      |      |      |
|---|---|---|---|---|-------------------------------------|---------------|--|------|------|------|------|
|   |   |   |   |   |                                     |               | D  | E    | F    | G    |      |
| <br>5 razze in alluminio<br>5-spoke aluminium<br>5 branches alu<br>5-Stern Alu Fußkreuz<br>estrella en aluminio | <br>d.65 gommate<br>soft d.65 mm<br>d.65mm gommées<br>weiche d.65 mm<br>ruedas goma diam.65   |   | Medium  | M-L                                     | <b>DR0097</b>                       | 21,80         | 1334   | 1339 | 1342 | 1374 |      |
|   |   |   |   | M-L                                     | <b>DR0085</b>                       | 21,90         | 1344   | 1349 | 1353 | 1392 |      |
|   |   |   | RAL 9005  | High                                    | M-L                                 | <b>DR0176</b> | 21,80  | 1334 | 1339 | 1342 | 1374 |
|   |   |   |   |   | M-L                                 | <b>DR0177</b> | 21,90  | 1344 | 1349 | 1353 | 1392 |
| <br>5 razze in ferro<br>5-spoke iron<br>5 branches en métal<br>5-Stern es Eisen Fußkreuz<br>estrella en metal   | <br>d.50mm autofrenanti gommate<br>soft self-braking d.50mm<br>d.50 mm gommées autofreinante<br>weiche gebremste D.50 mm<br>ruedas goma diam.50 autofreno |   | Medium  | M-L                                     | <b>DR0058</b>                       | 23,40         | 1463   | 1468 | 1473 | 1505 |      |
|   |   |   |   | M-L                                     | <b>DR0040</b>                       | 23,50         | 1475   | 1480 | 1483 | 1519 |      |
|   |   |   | RAL 9005  | High                                    | M-L                                 | <b>DR0178</b> | 23,40  | 1406 | 1411 | 1416 | 1448 |
|   |   |   |   |   | M-L                                 | <b>DR0179</b> | 23,50  | 1418 | 1423 | 1426 | 1462 |

\* DISPONIBILE ANCHE IN  
 ALSO AVAILABLE  
 ÉGALEMENT DISPONIBLE EN  
 ERHÄLTlich AUCH IN  
 TAMBIÉN DISPONIBLE EN



# DRESSCHAIR

## OPTIONALS

| OPZIONE<br>OPTIONALS<br>OPTIONS<br>OPTIONEN<br>OPCIONES  | VARIANTE<br>VARIANT<br>VARIANTE<br>VARIANTE<br>VARIANTE  | CODICE<br>CODE<br>CODE<br>ARTIKEL<br>CÓDIGO | KG   | PREZZO<br>PRICE<br>PRIX<br>PREIS<br>PRECIO | TESSUTI/FINITURE<br>UPHOLSTERIES/FINISHING<br>REVETEMENTS<br>STOFFGRUPPE<br>TAPICERIAS |     |     |     |     |
|--|--|---|------|--|--|-----|-----|-----|-----|
|  |  |   |      |  | D  | E   | F   | G   | H   |
|                   | FOR EVERY<br>DRESSCHAIR  | <b>XH003</b>                                | 0,20 |  |  |     | 25  | 25  | 25  |
| <b>MEDIUM</b><br> | ONLY FOR<br>MESH BACKREST  | <b>XC016</b>                                | 0,50 |  | 98   | 111 | 117 | 189 | 273 |
| <b>HIGH</b><br>   | ONLY FOR<br>MESH BACKREST  | <b>XC014</b>                                | 0,50 |  | 104  | 118 | 124 | 208 | 300 |
|                   | FOR EVERY<br>DRESSCHAIR  | <b>XR006</b>                                | 0,30 | 35   |  |     |     |     |     |
|                  | Small<br>Desk Pad<br>50x35 cm FOR EVERY<br>DRESSCHAIR  | <b>XA020</b>                                | 2,30 |  |  |     |     | 130 |     |
|                 | Large<br>Desk Pad<br>80x50 cm FOR EVERY<br>DRESSCHAIR  | <b>XA021</b>                                | 5,30 |  |  |     |     | 246 |     |
|                 | Sedile Comfort<br>Comfort Seats<br>Assise Confort<br>Komfort Sitz<br>Asiento Confortable                           | <b>XD018</b>                                | 0,60 | 25   |  |     |     |     |     |
|                 | SEAT WITH<br>NEGATIVE INCLINATION<br><br>ONLY FOR <b>SynchroPlus</b><br><small>TECH INSIDE. SIMPLE OUTSIDE</small> | <b>XM007</b>                                | 1,30 | 35   |  |     |     |     |     |

 MOVING

\* DISPONIBILE ANCHE CON  
 ALSO AVAILABLE WITH  
 ÉGALEMENT DISPONIBLE AVEC  
 ERHÄLTlich AUCH MIT  
 TAMBIÉN DISPONIBLE CON



d.65 mm gommate forate  
 self-braking d.65 mm perforated  
 d.65 mm autofreinante perforé  
 gebremste Rollen Design D.65 mm  
 diam.65 autofreno perforado

**+100€**

# FORMA

dea: *Pietro Lovato*



## 1. SCHIENALE:

Schienale in spugna schiumata a freddo con struttura portante in tubo quadro d'acciaio, 15x15mm, rivestito. Supporto lombare integrato regolabile in altezza (opzione)

## 2. BRACCIOLI:

- Bracciolo fisso in piatto d'acciaio, 30x5mm, finitura cromata (15µm) rivestito
- Bracciolo regolabile in tubo ellittico d'acciaio, 40x20mm, finitura cromata (15µm) o verniciata a polveri, con top in poliuretano morbido
- Bracciolo regolabile 4D con top morbido in poliuretano, regolazione 360° silenziosa
- Bracciolo regolabile in poliamide, finitura nera, con top in poliuretano morbido

## 3. SEDILE:

Sedile in polipropilene imbottito con spugna, rivestito

## 4. MECCANISMO:

- SynchroTeK cromato o nero, comando elevazione a gas, regolazione tensione schienale: inclinazione 26°sch, 10,5°sed. in 5 posizioni con antishock, inclinazione negativa sed. 4,5° traslazione sed. 6cm in 5 posizioni
- SynchroPlus+, comando elevazione a gas, regolazione tensione schienale, inclinazione 20°sch, 8°sed. in 5 posizioni con antishock, traslazione sed. 6cm in 5 posizioni

## 5. GAS:

- Regolabile in altezza, rotazione, finitura cromata
- Regolabile in altezza, rotazione, finitura cromata, molleggio

**6. BASE:** Base 5 razze in alluminio, Ø 710mm, finitura lucida

## 7. RUOTE:

Ø 65mm, gommato o autofrenanti e gommato, finitura nera.

## 1. BACKREST:

Cold injected foam padded backrest steel square bar 15x15mm structure, upholstery. Integrated lumbar support, height adjustable (optional)

## 2. ARMREST:

- Steel plate fixed armrest, 30x5mm, chromed finish (15µm), upholstered
- Height adj. Armrest, Ellipt. Steel tube 40x20mm, chromed finish (15µm) or powder coated, polyamide pad, black finish or soft polyurethane pad
- 4D Armrest, soft polyurethane pad, soundless adjustment 360°
- Black Polyamide adj. armrest, black polyamide top or soft black polyurethane pad

## 3. SEAT:

Polypropylene seat, foam padded, upholstery

## 4. MECHANISM:

- Chromed or black SynchroTeK, gas lift height adj. Backrest tension adj. Backrest inclination: 26° in 5 positions with antishock; Seat inclination: 10.5°. Negative seat inclination: 4.5°. Sliding seat device 6cm in 5 positions
- SynchroPlus+, gas lift height adj. Backrest tension adj. backrest inclination 20° in 5 locking position with antishock, seat inclination 8°. Sliding seat device 6cm in 5 positions

## 5. GAS LIFT:

- Height adjustable, swivel, chromed finish
- Height adjustable, swivel, chromed finish, shock absorber springs

## 6. BASE:

- Polished aluminium 5 spoke base, Ø 710 mm

## 7. CASTORS:

- Ø 65mm self-braking castors, or soft self-bracking. Black finish

## 1. DOSSIER:

Dossier en mousse moulée à froids avec châssis en tube d'acier carré, 15x15mm, tapissé. Soutien lombaire intégré réglable en hauteur (option)

## 2. ACCODOIR:

- Accoudoir fixe plat en acier, 30x5mm, finition chromé (15µm) tapissé
- Accoudoir réglable en tube d'acier elliptique, 40x20mm, finition chromé (15µm) ou verni époxy, manchette en polyamide, finition noir ou en polyuréthane souple
- Accoudoir 4D manchette en polyuréthane souple, pivotant 360°, réglage silencieux
- Accoudoir réglable en polyamide, finition noir, manchette en polyamide, finition noir ou en polyuréthane souple.

## 3. ASSISE:

Assise en polypropylène rembourrée de mousse moulée à froids, tapissée

## 4. MECANISME:

- SynchroTeK chromé ou noir, réglage en hauteur, réglage de tension, inclinaison dossier 26°et assise 10,5°, en 5 positions avec système antichoc, inclinaison négative assise 4,5°, profondeur d'assise 6 cm en 5 positions
- SynchroPlus+, réglage en hauteur, réglage de tension, inclinaison dossier 20°et assise 8°, en 5 positions avec système anti-choc, profondeur d'assise 6 cm en 5 positions

## 5. VERIN A GAZ:

- Réglable en hauteur, pivotant, finition chromé
- Réglable en hauteur, pivotant, finition chromé, amortisseur

## 6. PIÈTEMENT:

Piètement 5 branches alu poli, Ø 710mm

## 7. ROULETTES:

Roulettes Ø 65mm, gommées ou autofrenantes et gommées, finition noir

## 1. RÜCKENLEHNE:

Rückenlehne aus Vierkant Stahlrahmen, 15x15mm, ausgepolstert mit kaltgeschäumten Polyurethan (optional: integrierte höhenverstellbare Lumbalstütze)

## 2. ARMLEHNEN:

- Feste Armlehne aus Flachstahl 30x5 mm, verchromt (15µm) Gepolstert
- Verstellbare Armlehne aus Ellipt. Stahlrohr, 40x20mm, verchromt (15µm) oder pulverbeschichtet, schwarze Polyamid Armauflage oder weichen Polyurethan
- 4D Armlehne schwarz, PU Armauflage, verschiebbar, geräuschlos 360° drehbar
- Verstellbare schwarze Polyamid Armlehne mit Polyamid Armauflage oder mit weiche Polyurethan Armauflage

## 3. SITZ:

Polypropylen Sitz, ausgepolstert mit kaltgeschäumten Polyurethan, mit Stoffbezug

## 4. MECHANIK:

- SynchroTeK verchromt oder schwarz, Gaslift Höhenverstellung, Rückenlehne mit Spannungsregler, 26°Rück-enlehneigung, 10,5°Sitzneigung, negative Sitzneigung 4,5°, 5-stufige Einstellungsverstellung mit 5 Positionen
- SynchroPlus+, Gaslift Höhenverstellung, Rückenlehne mit Spannungsregler, 20°Rück-enlehneigung, 8°Sitzneigung, 5-stufige Einstellungsverstellung mit 5 Positionen

## 5. GASFEDER:

- Sitzhöhenverstellung, drehbar, verchromt
- Sitzhöhenverstellung, drehbar, verchromt, mit Stoßdämpfende Feder

## 6. GESTELL:

5-Stern Alu poliertes Fußkreuz, Ø 710 mm

## 7. ROLLEN:

Ø 65 mm gebremste, oder weiche gebremste Rollen, schwarz

## 1. RESPALDO:

Respaldo de espuma inyectada a frío con estructura de soporte en tubo de acero cuadrado, 15x15 mm, tapizado. Soporte lumbar integrado, ajustable en altura (opción)

## 2. BRAZOS:

- Brazos fijos en chapa de acero, 30x5 mm, acabado cromado (15µm) tapizado
- Brazos ajustables en tubo de acero elíptico, 40x20 mm, acabado cromado (15µm) o con pintado en polvo negro, con top de poliamida, acabado negro o top de poliuretano suave
- Brazos 4D, almohadilla en poliuretano suave, ajuste 360° sin sonido
- Brazos ajustables en poliamida, acabado negro, con top de poliamida, acabado negro o top de poliuretano suave

## 3. ASIENTO:

Asiento de polipropileno acolchado con espuma, tapizado

## 4. MECANISMO:

- SynchroTeK cromado o negro, control de elevación de gas, ajuste de la tensión de respaldo: inclinación de 26° resp. 10,5° asiento. en 5 posiciones con antishock, inclinación negativa asiento. 4,5° desplazamiento asiento. 6cm en 5 posiciones
- SynchroPlus+, control de elevación de gas, ajuste de tensión posterior, inclinación respaldo 20° . 8° asiento En 5 posiciones con antishock, desplazamiento asiento 6cm en 5 posiciones.

## 5. GAS:

- Ajustable en altura, rotación, acabado cromado.
- Ajustable en altura, rotación, acabado cromado, resortes

## 6. BASE:

base de 5 estrellas en aluminio, Ø 710 mm, acabado pulido

## 7. RUEDAS:

Ø 65mm, blandas o autofrenado y blandas, acabado negro.



# FORMA

IMBOTTITA, MOLLE SEBILE  
UPHOLSTERED, SEAT SPRINGS  
REMBOURRÉ, RESSORTS ASSISE  
GEPOLSTERT, FEDERKERN IM SITZ  
TAPIZADA, MUELLAS ASIENTO

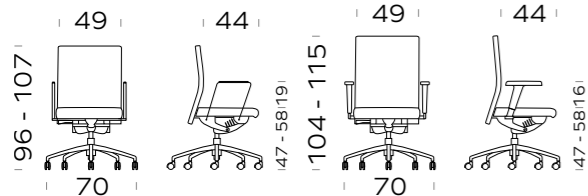

Mechanism: **SynchroPlus**  
TECH INSIDE, SIMPLE OUTSIDE  
Slide

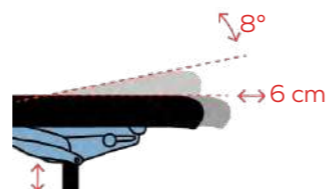

Blocco oscillante, Regolazione altezza/tensione, Regolazione in profondità del sedile  
(Un-)locking device, Height/tension adjustment, Depth adjustment of the seat  
Système de blocage-déblocage de l'oscillation, Réglage en hauteur/ d'intensité, Réglage en profondeur de l'assise  
Blockierung der Rückenlehne /Spannungsregler / Höhenverstellung, Sitztiefenverstellung  
Sistema de bloqueo-desbloqueo del respaldo, Ajuste de altura/tensión, Ajuste de profundidad del asiento

# FORMA

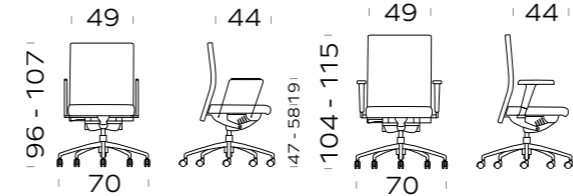

Mechanism: **SynchroTek**  
Slide Neg

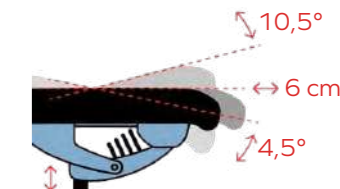

Blocco oscillante, Regolazione altezza/tensione, Regolazione in profondità del sedile, Inclinazione negativa  
(Un-)locking device, Height/tension adjustment, Depth adjustment of the seat, Negative inclination  
Système de blocage-déblocage de l'oscillation, Réglage en hauteur/ d'intensité, Réglage en profondeur de l'assise, Inclinasion négative  
Blockierung der Rückenlehne /Spannungsregler / Höhenverstellung, Sitztiefenverstellung, Sitzneigungsverstellung  
Sistema de bloqueo-desbloqueo del respaldo, Ajuste de altura/tensión, Ajuste de profundidad del asiento, Inclinación negativa

| BASE<br>BASE<br>PIÈTÈMENT<br>GESTELL<br>BASE | RUOTA/PIEDINO<br>CASTOR/FEET<br>ROULETTES/PATINS<br>ROLLEN/GLEITER<br>RUEDAS/PIES | STRUTTURA<br>STRUCTURE<br>STRUCTURE<br>STRUKTUR<br>ESTRUCTURA | SCHIENALE<br>BACKREST<br>DOSSIER<br>RÜCKENLEHNE<br>RESPALDO | CODICE<br>CODE<br>CODE<br>ARTIKEL<br>CODIGO | KG    | TESSUTI/FINITURE<br>UPHOLSTERIES/FINISHING<br>REVÊTEMENTS<br>STOFFGRUPPE<br>TAPICERÍAS |     |     |     |      |
|--|---|---|---|---|-------|--|-----|-----|-----|------|
|  |   |   |   |   |       | D  | E   | F   | G   | H    |
|  |   | Chromed   | Medium  | <b>FR0124</b>                               | 14,50 | 691  | 712 | 727 | 860 | 1085 |
|  |   |   | High  | <b>FR0041</b>                               | 15,10 | 703  | 726 | 741 | 882 | 1136 |
|  |   | RAL 9005<br>*   | Medium  | <b>FR0135</b>                               | 14,50 | 691  | 712 | 727 | 860 | 1085 |
|  |   |   | High  | <b>FR0136</b>                               | 15,10 | 703  | 726 | 741 | 882 | 1136 |
|  |   | RAL 9005<br>*   | Medium  | <b>FR0140</b>                               | 13,80 | 629  | 650 | 665 | 798 | 1023 |
|  |   |   | High  | <b>FR0141</b>                               | 14,40 | 641  | 664 | 679 | 820 | 1074 |
|  |   | RAL 9005<br>*   | Medium  | <b>FR0142</b>                               | 13,80 | 636  | 657 | 672 | 805 | 1030 |
|  |   |   | High  | <b>FR0143</b>                               | 14,40 | 648  | 671 | 686 | 827 | 1081 |

\* DISPONIBILE ANCHE IN  
ALSO AVAILABLE  
ÉGALEMENT DISPONIBLE EN  
ERHÄLTlich AUCH IN  
TAMBIÉN DISPONIBLE EN



| BASE<br>BASE<br>PIÈTÈMENT<br>GESTELL<br>BASE | RUOTA/PIEDINO<br>CASTOR/FEET<br>ROULETTES/PATINS<br>ROLLEN/GLEITER<br>RUEDAS/PIES | STRUTTURA<br>STRUCTURE<br>STRUCTURE<br>STRUKTUR<br>ESTRUCTURA | SCHIENALE<br>BACKREST<br>DOSSIER<br>RÜCKENLEHNE<br>RESPALDO | CODICE<br>CODE<br>CODE<br>ARTIKEL<br>CODIGO | KG    | TESSUTI/FINITURE<br>UPHOLSTERIES/FINISHING<br>REVÊTEMENTS<br>STOFFGRUPPE<br>TAPICERÍAS |      |      |      |      |
|--|---|---|---|---|-------|--|------|------|------|------|
|  |   |   |   |   |       | D  | E    | F    | G    | H    |
|  |   | Chromed   | Medium  | <b>FR0100</b>                               | 18,50 | 993  | 1016 | 1032 | 1162 | 1386 |
|  |   |   | High  | <b>FR0012</b>                               | 19,10 | 1007   | 1031 | 1048 | 1187 | 1440 |
|  |   | RAL 9005<br>*   | Medium  | <b>FR0137</b>                               | 18,50 | 993  | 1016 | 1032 | 1162 | 1386 |
|  |   |   | High  | <b>FR0138</b>                               | 19,10 | 1007   | 1031 | 1048 | 1187 | 1440 |

\* DISPONIBILE ANCHE IN  
ALSO AVAILABLE  
ÉGALEMENT DISPONIBLE EN  
ERHÄLTlich AUCH IN  
TAMBIÉN DISPONIBLE EN



# FORMA

## OPTIONALS

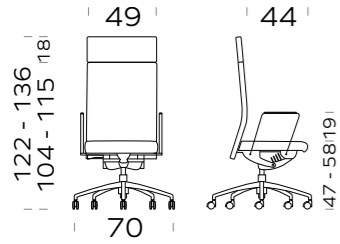

| OPZIONE<br>OPTIONALS<br>OPTIONEN<br>OPCIONES | VARIANTE<br>VARIANT<br>VARIANTE<br>VARIANTE | CODICE<br>CODE<br>ARTIKEL<br>CÓDIGO | KG   | PREZZO<br>PRICE<br>PRIX<br>PREIS<br>PRECIO | TESSUTI/FINITURE<br>UPHOLSTERIES/FINISHING<br>REVETEMENTS<br>STOFFGRUPPE<br>TAPICERIAS |     |     |     |     |
|--|---|-------------------------------------|------|--|--|-----|-----|-----|-----|
|  |   |                                     |      |  | D  | E   | F   | G   | H   |
|  | <br>Chromed                                 | <b>XB001</b>                        | 2,00 | 187  |  |     |     |     |     |
|  | *<br>RAL 9005                               | <b>XB105</b>                        | 2,00 | 187  |  |     |     |     |     |
|  | <br>Chromed                                 | <b>XB002</b>                        | 2,20 |  | 205  | 205 | 205 | 205 | 205 |
|  | *<br>RAL 9005                               | <b>XB102</b>                        | 2,20 |  | 205  | 205 | 205 | 205 | 205 |
|  | <b>2D SOFT</b>                              | <b>XB094</b>                        | 2,60 | 113  |  |     |     |     |     |
| *  | <b>2D SOFT</b>                              | <b>XB022</b>                        | 1,60 | 61   |  |     |     |     |     |
| *  | <b>3D SOFT</b>                              | <b>XB023</b>                        | 1,60 | 92   |  |     |     |     |     |
|  | <b>3D SOFT</b>                              | <b>XB087</b>                        | 2,50 | 145  |  |     |     |     |     |
| *  | <b>4D EXTRASOFT</b>                         | <b>XB089</b>                        | 2,60 | 102  |  |     |     |     |     |
|  | <b>4D EXTRASOFT</b>                         | <b>XB090</b>                        | 2,60 | 161  |  |     |     |     |     |

\* DISPONIBILE ANCHE IN  
ALSO AVAILABLE  
ÉGALEMENT DISPONIBLE EN  
ERHÄLTlich AUCH IN  
TAMBIÉN DISPONIBLE EN



RAL 9016



RAL 1012



RAL 3012



RAL 6021



RAL 7032



RAL 7046

# FORMA

## OPTIONALS

| OPZIONE<br>OPTIONALS<br>OPTIONEN<br>OPCIONES | VARIANTE<br>VARIANT<br>VARIANTE<br>VARIANTE  | CODICE<br>CODE<br>ARTIKEL<br>CÓDIGO | KG   | PREZZO<br>PRICE<br>PRIX<br>PREIS<br>PRECIO | TESSUTI/FINITURE<br>UPHOLSTERIES/FINISHING<br>REVETEMENTS<br>STOFFGRUPPE<br>TAPICERIAS |    |    |     |     |
|--|--|-------------------------------------|------|--|--|----|----|-----|-----|
|  |  |                                     |      |  | D  | E  | F  | G   | H   |
|  | Sedile Comfort<br>Comfort Seats<br>Assise Confort<br>Komfort Sitz<br>Asiento Confortable                           | <b>XD018</b>                        | 0,60 | 25   |  |    |    |     |     |
|  | SEAT WITH NEGATIVE<br>INCLINATION<br>ONLY FOR <b>SynchroPlus</b>   | <b>XM007</b>                        | 1,30 | 35   |  |    |    |     |     |
|  | Poggiatesta<br>Headrest<br>Appui-tête<br>Kopfstütze<br>Reposacabezas   | <b>XT004</b>                        | 0,80 |  | 93   | 93 | 95 | 110 | 141 |
|  | Supporto lombare<br>Lumbar support<br>Soutien lombaire<br>Lumbalstütze<br>Soporte lombar<br><b>HIGH BACKREST</b>   | <b>XR002</b>                        | 0,30 | 38   |  |    |    |     |     |
|  | Supporto lombare<br>Lumbar support<br>Soutien lombaire<br>Lumbalstütze<br>Soporte lombar<br><b>MEDIUM BACKREST</b> | <b>XR003</b>                        | 0,30 | 38   |  |    |    |     |     |
|  | Small<br>Desk Pad<br>50x35 cm  | <b>XA020</b>                        | 2,30 |  |  |    |    | 130 |     |
|  | Large<br>Desk Pad<br>80x50 cm  | <b>XA021</b>                        | 5,30 |  |  |    |    | 246 |     |

GIADA  
idea: *Pietro Lovato*



## TECHNICAL INFORMATION

### 1. SCHIENALE:

Schienale in spugna schiumata a freddo con struttura portante in tubo tondo d'acciaio, Ø 16mm, rivestito. Supporto lombare integrato regolabile in altezza (opzione).

### 2. SEDILE:

Sedile in polipropilene imbottito con spugna schiumata a freddo, rivestito

### 3. MECCANISMO:

SynchroPlus+, comando elevazione a gas, regolazione tensione schienale, inclinazione 20°sch. 8°sed. in 5 posizioni con antishock, traslazione sed. 6cm in 5 posizioni

### 4. GAS:

- Regolabile in altezza, rotazione, finitura cromata, molleggio

### 5. BASE:

- 5 razze in alluminio, Ø 710mm, finitura lucida
- 5 razze in ferro, Ø 710mm, finitura cromata (15µm)

### 6. RUOTE:

- Ø 65mm, gommato o autofrenanti e gommato, finitura nera.
- Ø 50mm, autofrenanti o autofrenanti e gommato, finitura cromata

### 1. BACKREST:

Ø25mm shaped steel tube backrest, chromed finish (15µm), mesh upholstered or foam padded and upholstery. Integrated lumbar support, height adjustable (optional)

### 2. SEAT:

Polypropylene seat, cold injected foam padded, upholstery

### 3. MECHANISM:

SynchroPlus+, gas lift height adj. Backrest tension adj. backrest inclination 20° in 5 locking position with antishock, seat inclination 8°. Sliding seat device 6cm in 5 positions

### 4. GAS LIFT:

- Height adjustable, swivel, chromed finish, shock absorber springs

### 5. BASE:

- Polished aluminium 5 spoke base, Ø 710 mm
- Iron 5 spoke base, Ø 710 mm chromed finish (15µm)

### 6. CASTORS:

- Ø 65mm self-braking castors, or soft self-bracking. Black finish
- Ø 50 mm self-braking castors, or soft self-bracking. Chromed finish

### 1. DOSSIER:

Dossier en mousse moulée à froids avec châssis en tube d'acier rond, Ø 16mm, tapissé. Soutien lombaire intégré réglable en hauteur (option)

### 2. ASSISE:

Assise en polypropylène rembourrée de mousse moulée à froids, tapissée

### 3. MECANISME:

SynchroPlus+, réglage en hauteur, réglage de tension, inclination dossier 20°et assise 8°, en 5 positions avec système anti-choc, profondeur d'assise 6 cm en 5 positions

### 4. VERIN A GAZ:

- Réglable en hauteur, pivotant, finition chromé, amortisseur

### 5. PIÈTEMENT:

- Piètement 5 branches alu poli, Ø 710mm
- Piètement 5 branches en métal, Ø 710mm, finition chromé (15µm)

### 6. ROULETTES:

- Roulettes Ø 65mm, gommées ou autofreinantes et gommées, finition noir
- Roulettes Ø 50mm, autofreinantes ou autofreinantes et gommées, finition chromé

### 1. RÜCKENLEHNE:

Kaltgeschäumten Polyurethan, mit Stoffbezug. Ø 16mm Stahlrohrschale. Integrierte höhenverstellbare Lumbalstütze (option)

### 2. SITZ:

Polypropylen Sitz, ausgepolstert mit Kaltgeschäumten Polyurethan, mit Bezug

### 3. MECHANIK:

SynchroPlus+, Gaslift Höhenverstellung, Rückenlehne mit Spannungsregler, 20°Rückenlehneigung, 8°Sitzneigung, 5-stufige Einstellung mit Antishock, 6 cm Sitztiefenverstellung mit 5 Positionen

### 4. GASFEDER:

- Sitzhöhenverstellung, drehbar, verchromt, mit Stoßdämpfende Feder

### 5. GESTELL:

- 5-Stern Alu poliertes Fußkreuz, Ø 710 mm
- 5-Stern Eisen Fußkreuz, Ø 710mm verchromt (15µm)

### 6. ROLLEN:

- Ø 65 mm gebremste, oder weiche gebremste Rollen, schwarze
- Ø 50 mm gebremste, oder weiche gebremste Rollen, verchromt

### 1. RESPALDO:

Respaldo de espuma inyectada a frio con estructura de soporte en tubo de acero redondo, Ø 16 mm, tapizado. Soporte lumbar integrado, ajustable en altura (opción)

### 2. ASIENTO:

Asiento de polipropileno acolchado con espuma inyectada a frio, tapizado

### 3. MECANISMO:

SynchroPlus+, control de elevación de gas, ajuste de tensión posterior, inclinación respaldo 20°. 8° asiento En 5 posiciones con antishock.

### 4. GAS:

- Ajustable en altura, rotación, acabado cromado, resorte.

### 5. BASE:

- 5 radios en aluminio, Ø 710mm, acabado brillante.
- 5 radios de hierro, Ø 710 mm, acabado cromado (15µm).

### 6. RUEDAS:

- Ø 65mm, blandas o autofrenado y blandas, acabado negro.
- Ø 50 mm, blandas o autofrenado y blandas, acabado cromado



# GIADA

IMBOTTITA  
UPHOLSTERED  
REMBOURRÉ  
GEPOLSTERT  
TAPIZADA

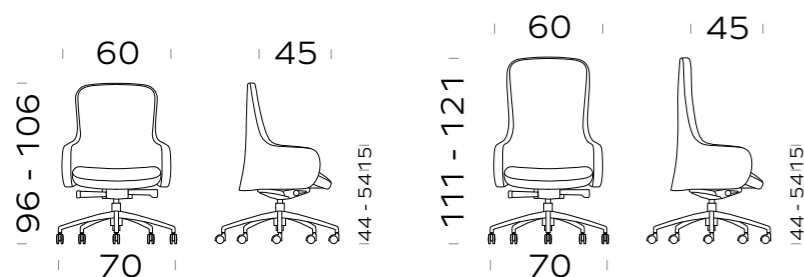

Mechanism: **SynchroPlus**  
TECH INSIDE. SIMPLE OUTSIDE

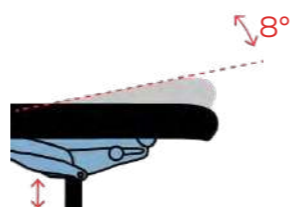

Blocco oscillante, Regolazione altezza/tensione  
(Un-)locking device, Height/tension adjustment  
Système de blocage-déblocage de l'oscillation, Réglage en hauteur/ d'intensité  
Blockierung der Rückenlehne /Spannungsregler / Höhenverstellung  
Sistema de bloqueo-desbloqueo del respaldo, Ajuste de altura/tensión

# GIADA

IMBOTTITA  
UPHOLSTERED  
REMBOURRÉ  
GEPOLSTERT  
TAPIZADA

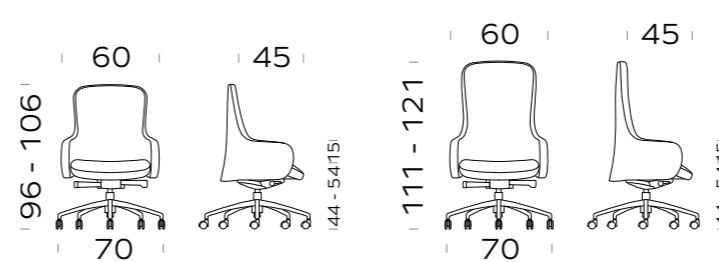

Mechanism: **SynchroPlus**  
TECH INSIDE. SIMPLE OUTSIDE  
Slidè

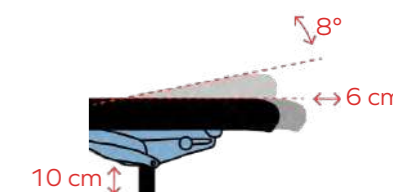

Blocco oscillante, Regolazione altezza/tensione, Regolazione in profondità del sedile  
(Un-)locking device, Height/tension adjustment, Depth adjustment of the seat  
Système de blocage-déblocage de l'oscillation, Réglage en hauteur/ d'intensité, Réglage en profondeur de l'assise  
Blockierung der Rückenlehne /Spannungsregler / Höhenverstellung, Sitztiefenverstellung  
Sistema de bloqueo-desbloqueo del respaldo, Ajuste de altura/tensión, Ajuste de profundidad del asiento

| BASE<br>BASE<br>PIETEMENT<br>GESTELL<br>BASE   | RUOTA/PIEDINO<br>CASTOR/FEET<br>ROULETTES/PATINS<br>ROLLEN/GLEITER<br>RUEDAS/PIES   | STRUTTURA<br>STRUCTURE<br>STRUCTURE<br>STRUKTUR<br>ESTRUCTURA | SCHIENALE<br>BACKREST<br>DOSSIER<br>RÜCKENLEHNE<br>RESPALDO | CODICE<br>CODE<br>ARTIKEL<br>CÓDIGO | KG    | TESSUTI/FINITURE<br>UPHOLSTERIES/FINISHING<br>REVETEMENTS<br>STOFFGRUPPE<br>TAPICERÍAS |      |      |      |      |
|--|---|---|---|-------------------------------------|-------|--|------|------|------|------|
|  |   |   |   |                                     |       | D  | E    | F    | G    | H    |
| <br>5 razze design poliammide<br>5-spoke polyamide design<br>design 5 branches polyamide<br>5 - Stern Polyamid Design Fußkreuz<br>design estrella en poliamida | <br>d.50mm autofrenanti gommate<br>soft self-braking d.50mm<br>d.50 mm gommées autofreinante<br>weiche gebremste D.50 mm<br>ruedas goma diam.50 autofreno |   | Medium  | <b>GD0114</b>                       | 18,30 | 831  | 856  | 873  | 1029 | 1309 |
|  |   |   | High  | <b>GD0115</b>                       | 19,10 | 869  | 899  | 924  | 1115 | 1473 |
| <br>5 razze in alluminio<br>5-spoke aluminium<br>5 branches alu<br>5 - Stern Alu Fußkreuz<br>estrella en aluminio  | <br>d.65 gommate<br>soft d.65 mm<br>d.65mm gommées<br>weiche D.65 mm<br>ruedas goma diam.65   |   | Medium  | <b>GD0085</b>                       | 16,70 | 899  | 924  | 942  | 1097 | 1376 |
|  |   |   | High  | <b>GD0077</b>                       | 17,50 | 938  | 967  | 993  | 1183 | 1542 |
| <br>5 razze in ferro<br>5-spoke iron<br>5 branches en métal<br>5-Stern es Eisen Fußkreuz<br>estrella en metal  | <br>d.50mm autofrenanti gommate<br>soft self-braking d.50mm<br>d.50 mm gommées autofreinante<br>weiche gebremste D.50 mm<br>ruedas goma diam.50 autofreno |   | Medium  | <b>GD0134</b>                       | 16,70 | 899  | 924  | 942  | 1097 | 1376 |
|  |   |   | High  | <b>GD0135</b>                       | 17,50 | 938  | 967  | 993  | 1183 | 1542 |
| <br>5 razze in ferro<br>5-spoke iron<br>5 branches en métal<br>5-Stern es Eisen Fußkreuz<br>estrella en metal  | <br>d.50mm autofrenanti gommate<br>soft self-braking d.50mm<br>d.50 mm gommées autofreinante<br>weiche gebremste D.50 mm<br>ruedas goma diam.50 autofreno |   | Medium  | <b>GD0089</b>                       | 18,30 | 1045   | 1070 | 1090 | 1244 | 1524 |
|  |   |   | High  | <b>GD0081</b>                       | 19,10 | 1083   | 1115 | 1139 | 1330 | 1690 |
| <br>5 razze in ferro<br>5-spoke iron<br>5 branches en métal<br>5-Stern es Eisen Fußkreuz<br>estrella en metal  | <br>d.50mm autofrenanti gommate<br>soft self-braking d.50mm<br>d.50 mm gommées autofreinante<br>weiche gebremste D.50 mm<br>ruedas goma diam.50 autofreno |   | Medium  | <b>GD0136</b>                       | 18,30 | 988  | 1013 | 1033 | 1187 | 1467 |
|  |   |   | High  | <b>GD0137</b>                       | 19,10 | 1026   | 1058 | 1082 | 1273 | 1633 |

\* DISPONIBILE ANCHE IN  
ALSO AVAILABLE  
ÉGALEMENT DISPONIBLE EN  
ERHÄLTICH AUCH IN  
TAMBIÉN DISPONIBLE EN



RAL 9016



RAL 6021



RAL 1012



RAL 7032



RAL 3012



RAL 7046

| BASE<br>BASE<br>PIETEMENT<br>GESTELL<br>BASE   | RUOTA/PIEDINO<br>CASTOR/FEET<br>ROULETTES/PATINS<br>ROLLEN/GLEITER<br>RUEDAS/PIES   | STRUTTURA<br>STRUCTURE<br>STRUCTURE<br>STRUKTUR<br>ESTRUCTURA | SCHIENALE<br>BACKREST<br>DOSSIER<br>RÜCKENLEHNE<br>RESPALDO | CODICE<br>CODE<br>ARTIKEL<br>CÓDIGO | KG    | TESSUTI/FINITURE<br>UPHOLSTERIES/FINISHING<br>REVETEMENTS<br>STOFFGRUPPE<br>TAPICERÍAS |      |      |      |      |
|--|---|---|---|-------------------------------------|-------|--|------|------|------|------|
|  |   |   |   |                                     |       | D  | E    | F    | G    | H    |
| <br>5 razze design poliammide<br>5-spoke polyamide design<br>design 5 branches polyamide<br>5 - Stern Polyamid Design Fußkreuz<br>design estrella en poliamida | <br>d.50mm autofrenanti gommate<br>soft self-braking d.50mm<br>d.50 mm gommées autofreinante<br>weiche gebremste D.50 mm<br>ruedas goma diam.50 autofreno |   | Medium  | <b>GD0118</b>                       | 18,30 | 851  | 874  | 894  | 1048 | 1329 |
|  |   |   | High  | <b>GD0119</b>                       | 19,10 | 889  | 919  | 943  | 1136 | 1495 |
| <br>5 razze in alluminio<br>5-spoke aluminium<br>5 branches alu<br>5 - Stern Alu Fußkreuz<br>estrella en aluminio  | <br>d.65 gommate<br>soft d.65 mm<br>d.65mm gommées<br>weiche D.65 mm<br>ruedas goma diam.65   |   | Medium  | <b>GD0098</b>                       | 16,70 | 919  | 943  | 962  | 1116 | 1398 |
|  |   |   | High  | <b>GD0096</b>                       | 17,50 | 958  | 987  | 1012 | 1203 | 1564 |
| <br>5 razze in ferro<br>5-spoke iron<br>5 branches en métal<br>5-Stern es Eisen Fußkreuz<br>estrella en metal  | <br>d.50mm autofrenanti gommate<br>soft self-braking d.50mm<br>d.50 mm gommées autofreinante<br>weiche gebremste D.50 mm<br>ruedas goma diam.50 autofreno |   | Medium  | <b>GD0138</b>                       | 16,70 | 919  | 943  | 962  | 1116 | 1398 |
|  |   |   | High  | <b>GD0139</b>                       | 17,50 | 958  | 987  | 1012 | 1203 | 1564 |
| <br>5 razze in ferro<br>5-spoke iron<br>5 branches en métal<br>5-Stern es Eisen Fußkreuz<br>estrella en metal  | <br>d.50mm autofrenanti gommate<br>soft self-braking d.50mm<br>d.50 mm gommées autofreinante<br>weiche gebremste D.50 mm<br>ruedas goma diam.50 autofreno |   | Medium  | <b>GD0099</b>                       | 18,30 | 1066   | 1090 | 1112 | 1265 | 1542 |
|  |   |   | High  | <b>GD0097</b>                       | 19,10 | 1103   | 1136 | 1159 | 1351 | 1711 |
| <br>5 razze in ferro<br>5-spoke iron<br>5 branches en métal<br>5-Stern es Eisen Fußkreuz<br>estrella en metal  | <br>d.50mm autofrenanti gommate<br>soft self-braking d.50mm<br>d.50 mm gommées autofreinante<br>weiche gebremste D.50 mm<br>ruedas goma diam.50 autofreno |   | Medium  | <b>GD0140</b>                       | 18,30 | 1009   | 1033 | 1055 | 1208 | 1485 |
|  |   |   | High  | <b>GD0141</b>                       | 19,10 | 1046   | 1079 | 1102 | 1294 | 1654 |

\* DISPONIBILE ANCHE IN  
ALSO AVAILABLE  
ÉGALEMENT DISPONIBLE EN  
ERHÄLTICH AUCH IN  
TAMBIÉN DISPONIBLE EN



RAL 9016



RAL 6021



RAL 1012



RAL 7032



RAL 3012







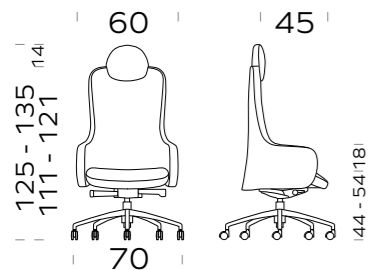

RAL 7046

# GIADA

## OPTIONALS



| OPZIONE<br>OPTIONALS<br>OPTIONS<br>OPTIONEN<br>OPCIONES                             | VARIANTE<br>VARIANT<br>VARIANTE<br>VARIANTE<br>VARIANTE  | CODICE<br>CODE<br>ARTIKEL<br>CÓDIGO | KG   | PREZZO<br>PRICE<br>PRIX<br>PREIS<br>PRECIO | TESSUTI/FINITURE<br>UPHOLSTERIES/FINISHING<br>REVÊTEMENTS<br>STOFFGRUPPE<br>TAPICERIAS |    |     |     |     |
|---|--|-------------------------------------|------|--|--|----|-----|-----|-----|
|   |  |                                     |      |  | D  | E  | F   | G   | H   |
|    | Poggiatesta<br>Headrest<br>Appui-tête<br>Kopfstütze<br>Reposacabezas<br><b>ONLY FOR HIGH BACKREST</b>              | <b>XT005</b>                        | 0,80 |  | 95   | 96 | 98  | 109 | 153 |
|    | Supporto lombare<br>Lumbar support<br>Soutien lombaire<br>Lumbalstütze<br>Soporte lombar<br><b>HIGH BACKREST</b>   | <b>XR004</b>                        | 0,30 | 38   |  |    |     |     |     |
|   | Supporto lombare<br>Lumbar support<br>Soutien lombaire<br>Lumbalstütze<br>Soporte lombar<br><b>MEDIUM BACKREST</b> | <b>XR005</b>                        | 0,30 | 38   |  |    |     |     |     |
|  | Small<br>Desk Pad<br>50x35 cm  | <b>XA020</b>                        | 2,30 |  |  |    | 130 |     |     |
|  | Large<br>Desk Pad<br>80x50 cm  | <b>XA021</b>                        | 5,30 |  |  |    | 246 |     |     |
|  | Molle sedile<br>Seat springs<br>Ressorts assise<br>Sitz Federkern<br>Resortes asientos                             | <b>XD005</b>                        | 0,80 | 37   |  |    |     |     |     |
|  | SEAT WITH<br>NEGATIVE INCLINATION<br><br>ONLY FOR <b>SynchroPlus</b><br>Slide →                                    | <b>XM007</b>                        | 1,30 | 35   |  |    |     |     |     |

\* DISPONIBILE ANCHE CON  
 ALSO AVAILABLE WITH  
 ÉGALEMENT DISPONIBLE AVEC  
 ERHÄLTICH AUCH MIT  
 TAMBIÉN DISPONIBLE CON



d.50 mm autofrenanti  
 self-braking d.50mm  
 d.50mm autofreinante  
 gebremste D.50mm  
 diam.50 autofreno

**SAME PRICE**

 MOVING

ATTIVA  
design: Ambostudio



### 1. SCHIENALE:

Schienale in tubo sagomato d'acciaio, Ø 25 mm, finitura cromata (15µm), in rete o imbottito con spugna e rivestito

### 2. BRACCIOLI:

Bracciolo fisso in piatto d'acciaio, 30x5mm, finitura cromata (15µm) e/o rivestito  
Bracciolo regolabile in tubo ellittico d'acciaio, 40x20mm, finitura cromata (15µm) o verniciata a polveri, con top in poliamide, finitura nera, finitura nera, o top in poliuretano morbido  
Bracciolo regolabile in 4D in tubo ovale d'acciaio, 45x25mm, finitura cromata, con top in poliuretano morbido  
Bracciolo regolabile in poliamide, finitura nera, con top in poliamide, finitura nera, o top in poliuretano morbido

### 3. SEDILE:

Sedile in polipropilene imbottito con spugna schiumata a freddo rivestito

### 4. MECCANISMO:

SynchroTeK cromato o nero, comando elevazione a gas, regolazione tensione schienale: inclinazione 26°sch. 10.5°sed. in 5 posizioni con antishock; Seat inclination: 10.5°. Negative seat inclination: 4.5°. Sliding seat device 6cm in 5 positions  
SynchroPlus+, comando elevazione a gas, regolazione tensione schienale, inclinazione 20°sch. 8°sed. in 5 posizioni con antishock, traslazione sed. 6cm in 5 posizioni  
Comando elevazione a gas, finitura nera

### 5. GAS:

Regolabile in altezza, rotazione, finitura cromata  
Regolabile in altezza, rotazione, finitura cromata, molleggio  
Altezza fissa, ritorno automatico, finitura cromata

### 6. BASE:

Base 5 razze in alluminio, Ø 710mm, finitura lucida  
Base 5 razze in ferro, Ø 710mm, finitura cromata (15µm)  
Base 4 razze in alluminio, Ø 630mm, finitura lucida

### 7. RUOTE/PIEDINI:

Ø 65mm, gommate o autofrenanti e gommate, finitura nera  
Ruote Ø 50mm, autofrenanti o autofrenanti e gommate, finitura cromata  
Piedini in polimero termoplastico, h. 68mm, finitura cromata (15µm)  
Piedini in polimero termoplastico, h. 25mm, finitura cromata (15µm)

### 1. BACKREST:

Shaped steel tube backrest, Ø 25 mm, chromed finish (15µm), mesh upholstered or foam padded and upholstery

### 2. ARMREST:

Steel plate fixed armrest, 30x5mm, chromed finish (15µm), upholstered or not  
Height adj., Armrest, Ellipt. Steel tube 40x20mm, chromed finish (15µm) or powder coated, polyamide pad, black finish or soft polyurethane pad.  
4D ADJ. ARMREST, in oval steel tube 45x25mm, chromed finish, soft polyurethane pad  
Black Polyamide adj. armrest, black polyamide top or soft black polyurethane pad

### 3. SEAT:

Polypropylene seat, cold injected foam padded, upholstery

### 4. MECHANISM:

Chromed or black SynchroTeK, gas lift height adj., Backrest tension adj., Backrest inclination: 26° in 5 positions with antishock; Seat inclination: 10.5°. Negative seat inclination: 4.5°. Sliding seat device 6cm in 5 positions  
SynchroPlus+, gas lift height adj., Backrest tension adj., backrest inclination 20° in 5 locking position with antishock, seat inclination 8°. Sliding seat device 6cm in 5 positions

### 5. GAS LIFT:

Height adjustable, swivel, chromed finish  
Height adjustable, swivel, chromed finish, shock absorber springs  
Not height adjustable, memory return cylinder, chromed finish

### 6. BASE:

Polished aluminium 5 spoke base, Ø 710 mm  
Iron 5 spoke base, Ø 710 mm chromed finish (15µm)  
Polished aluminium 4 spoke base, Ø 630 mm

### 7. CASTORS/FEET:

Ø 65mm self-braking castors, or soft self-bracking. Black finish  
Ø 50 mm self-braking castors, or soft self-bracking. Chromed finish  
h. 68mm Thermoplastic polymer gliders chromed finish (15µm)  
h. 25mm Thermoplastic polymer gliders chromed finish (15µm)

### 1. DOSSIER:

Dossier en tube d'acier formé, Ø 25 mm, finition chromée (15µm), en résille ou rembourré en mousse et revêtu

### 2. ACCOUDOIR:

Accoudoir fixe plat en acier, 30x5mm, finition chromé (15µm) tapissé ou non  
Accoudoir réglable en tube d'acier elliptique, 40x20mm, finition chromé (15µm) ou verni époxy, manchette en polyamide, finition noir ou en polyuréthane souple  
Accoudoir réglable en 4D en tube ovale d'acier, 45x25mm, finition chromé, manchette en polyuréthane souple  
Accoudoir réglable en polyamide, finition noir, manchette en polyamide, finition noir ou en polyuréthane souple

### 3. ASSISE:

Assise en polypropylène rembourrée de mousse moulée à froids, tapissée

### 4. MECANISME:

SynchroTeK chromé ou noir, réglage en hauteur, réglage de tension, inclinaison dossier 26°et assise 10.5°, en 5 positions avec système antichoc, inclinaison négative assise 4.5°, profondeur d'assise 6 cm en 5 positions  
Réglable en hauteur, finition noir  
SynchroPlus+, réglage en hauteur, réglage de tension, inclinaison dossier 20°et assise 8°, en 5 positions avec système anti-choc, profondeur d'assise 6 cm en 5 positions

### 5. VERIN A GAZ:

Réglable en hauteur, pivotant, finition chromé  
Réglable en hauteur, pivotant, finition chromé, amortisseur  
Hauteur fixe, retour automatique, finition chromé

### 6. PIÈTEMENT:

Piètement 5 branches alu poli, Ø 710mm  
Piètement 5 branches en métal, Ø 710mm, finition chromé (15µm)  
Piètement 4 branches alu poli, Ø 630mm

### 7. ROULETTES/PATINS:

Roulettes Ø 65mm, gommées ou autofrenantes et gommées, finition noir  
Roulettes Ø 50mm, autofrenantes et gommées, finition chromé  
Patins en polymère thermoplastique, h. 68mm, finition chromée (15µm)  
Patins polymère thermoplastique, h. 25mm, finition chromée (15µm)

### 1. RÜCKENLEHNE:

Gefarmte Stahlrohr Rückenlehne, Ø 25mm, verchromt (15µm), Netzbespannt oder mit Schaumstoffkissen mit überzug

### 2. ARMLEHNEN:

Feste Armlehne aus Flachstahl 30x5 mm, verchromt (15µm) Gepolstert oder nein  
Verstellbare Armlehne aus Ellipt. Stahlrohr, 40x20mm, verchromt (15µm) oder pulverbeschichtet, schwarze Polyamid Armauflage oder weichen Polyurethan  
4D verstellbare Armlehne aus ovales Stahlrohr, 45x25mm, verchromt (15µm) schwarze Polyamid weiche Armauflage  
Verstellbare schwarze Polyamid Armlehne mit Polyamid Armauflage oder mit weiche Polyurethan Armauflage

### 3. SITZ:

Polypropylen Sitz, ausgepolstert mit kaltgeschäumten Polyurethan, mit Bezug

### 4. MECHANIK:

SynchroTeK verchromt oder schwarz, Gaslift Höhenverstellung, Rückenlehne mit Spannungsregler, 26°Rückenlehneigung, 10.5°Sitzneigung, negative Sitzneigung 4.5°, 5-stufige Einstellung mit Antishock, 6 cm Sitztiefenverstellung mit 5 Positionen  
Schwarze Sitzhöhenverstellung  
SynchroPlus+, Gaslift Höhenverstellung, Rückenlehne mit Spannungsregler, 20°Rückenlehneigung, 8°Sitzneigung, 5-stufige Einstellung mit Antishock, 6 cm Sitztiefenverstellung mit 5 Positionen

### 5. GASFEDER:

Sitzhöhenverstellung, drehbar, verchromt  
Sitzhöhenverstellung, drehbar, verchromt, mit Stoßdämpfende Feder  
Ruckholmechanik ohne Sitzhöhenverstellung, verchromt

### 6. GESTELL:

5-Stern Alu poliertes Fußkreuz, Ø 710 mm  
5-Stern Eisen Fußkreuz, Ø 710mm verchromt (15µm)  
4-Stern Alu poliertes Fußkreuz, Ø 630 mm

### 7. ROLLEN/GLEITER

Ø 65 mm gebremste, oder weiche gebremste Rollen, schwarze  
Ø 50 mm gebremste, oder weiche gebremste Rollen, verchromt  
Thermoplastische Polymergleiter, H. 68 mm, verchromt (15 µm)  
Thermoplastische Polymergleiter, H. 25mm, verchromt (15 µm)

### 1. RESPALDO:

Respaldo de tubo de acero perfilado, Ø 25 mm, acabado cromado (15µm) en malla o acolchado con espuma y tapizado

### 2. BRAZOS:

Brazos fijos en chapa de acero, 30x5 mm, acabado cromado (15µm) tapizado o no  
brazos ajustables en tubo de acero elíptico, 40x20 mm, acabado cromado (15µm) o con pintado en polvo negro, con top de poliamida, acabado negro o top de poliuretano suave  
Brazos 4D ajustables en tubo de acero ovalado, 45x25 mm, acabado cromado, con top de poliuretano suave  
Brazos ajustables en poliamida, acabado negro, con top de poliamida, acabado negro o top de poliuretano suave

### 3. ASIENTO:

Asiento de polipropileno acolchado con espuma inyectado a frío, tapizado

### 4. MECANISMO:

SynchroTeK cromado o negro, control de elevación de gas, ajuste de la tensión de respaldo: inclinación de 26 ° resp. 10.5 ° asiento. en 5 posiciones con antishock, inclinación negativa asiento. 4.5 ° desplazamiento asiento. 6cm en 5 posiciones  
SynchroPlus+, control de elevación de gas, ajuste de tensión posterior, inclinación respaldo 20°. 8° asiento En 5 posiciones con antishock, desplazamiento asiento 6cm en 5 posiciones

### 5. GAS:

Ajustable en altura, rotación, acabado cromado  
Ajustable en altura, rotación, acabado cromado, resortes.  
Altura fija, retorno automático, acabado cromado

### 6. BASE:

Base de 5 estrellas en aluminio, Ø 710 mm, acabado pulido  
Base de 5 estrellas en hierro, Ø 710 mm, acabado cromado (15µm)  
Base de 4 radios en aluminio, Ø 630mm, acabado pulido

### 7. RUEDAS:

Ø 65mm, blandas o autofrenado y blandas, acabado negro.  
Ø 50mm, blandas o autofrenado y blandas, acabado pulido.  
Pies en polímero termoplástico, h. 68 mm, acabado cromado (15µm)  
Pies en polímero termoplástico, h. 25mm, acabado negro (15µm)



ID 1111209619

# ATTIVA

SCHIENALE IN RETE, TRAVERSO "C", MOLLE SEDILE  
 MESH BACKREST, "C" BAR, PACKED SPRINGS  
 DOSSIER EN RÉVILLE, TRAVERSE "C", RESORTS ASSISE  
 NETZ RÜCKENLEHNE, TRAVERSE "C", FEDERKERN IM SITZ  
 RESPALDO EN MALLA, TRANVERSA "C", MUELLAS ASIENTO

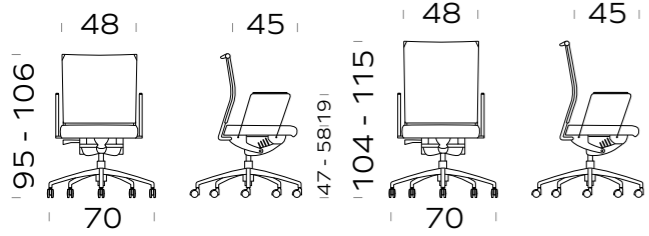

Mechanism: **SynchroPlus**  
 TECH INSIDE, SIMPLE OUTSIDE  
 Slidè

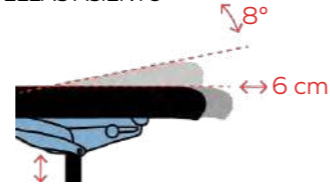

Blocco oscillante, Regolazione altezza/tensione, Regolazione in profondità del sedile  
 (Un-)locking device, Height/tension adjustment, Depth adjustment of the seat  
 Système de blocage-débloqué de l'oscillation, Réglage en hauteur/ d'intensité, Réglage en profondeur de l'assise  
 Blockierung der Rückenlehne /Spannungsregler / Höhenverstellung, Sitztiefenverstellung  
 Sistema de bloqueo-desbloqueo del respaldo, Ajuste de altura/tensión, Ajuste de profundidad del asiento

# ATTIVA

SCHIENALE IN RETE, TRAVERSO "C", MOLLE SEDILE  
 MESH BACKREST, "C" BAR, PACKED SPRINGS  
 DOSSIER EN RÉVILLE, TRAVERSE "C", RESORTS ASSISE  
 NETZ RÜCKENLEHNE, TRAVERSE "C", FEDERKERN IM SITZ  
 RESPALDO EN MALLA, TRANVERSA "C", MUELLAS ASIENTO

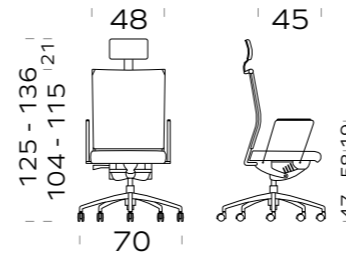

Mechanism: **SynchroTek**  
 Slidè Neg

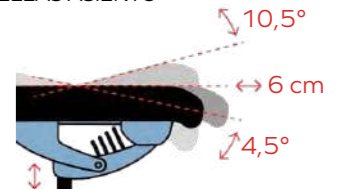

Blocco oscillante, Regolazione altezza/tensione, Regolazione in profondità del sedile, Inclinazione negativa  
 (Un-)locking device, Height/tension adjustment, Depth adjustment of the seat, Negative inclination  
 Système de blocage-débloqué de l'oscillation, Réglage en hauteur/ d'intensité, Réglage en profondeur de l'assise, Inclinaison négative  
 Blockierung der Rückenlehne /Spannungsregler / Höhenverstellung, Sitztiefenverstellung, Sitzneigungsverstellung  
 Sistema de bloqueo-desbloqueo del respaldo, Ajuste de altura/tensión, Ajuste de profundidad del asiento, Inclinación negativa

| BASE<br>BASE<br>PIETEMET<br>GESTELL<br>BASE | RUOTA/PIEDINO<br>CASTOR/FEET<br>ROULETTES/PATINS<br>RÖLLEN/GLEITER<br>RUEDAS/PIES | STRUTTURA<br>STRUCTURE<br>STRUCTURE<br>STRUKTUR<br>ESTRUCTURA | SCHIENALE<br>BACKREST<br>DOSSIER<br>RÜCKENLEHNE<br>RESPALDO | RETE<br>MESH<br>MAILLE<br>NETZ<br>MALLA | CODICE<br>CODE<br>ARTIKEL<br>CÓDIGO | KG    | TESSUTI/FINITURE<br>UPHOLSTERIES/FINISHING<br>REVETEMENTS<br>STOFFGRUPPE<br>TAPICERÍAS |     |     |      |      |
|---|---|---|---|---|-------------------------------------|-------|--|-----|-----|------|------|
|   |   |   |   |   |                                     |       | D  | E   | F   | G    | H    |
|   |   | Chromed   | Medium  | M-L                                     | AT0230                              | 13,70 | 834  | 840 | 845 | 879  | 941  |
|   |   |   | High  | M-L                                     | AT0039                              | 14,00 | 845  | 850 | 853 | 887  | 948  |
|   |   | RAL 9005  | Medium  | M-L                                     | AT0317                              | 13,70 | 834  | 840 | 845 | 879  | 941  |
|   |   |   | High  | M-L                                     | AT0318                              | 14,00 | 845  | 850 | 853 | 887  | 948  |
|   |   | Chromed   | Medium  | M-L                                     | AT0234                              | 15,30 | 959  | 965 | 968 | 1003 | 1065 |
|   |   |   | High  | M-L                                     | AT0043                              | 15,60 | 968  | 973 | 977 | 1012 | 1073 |
|   |   | RAL 9005  | Medium  | M-L                                     | AT0302                              | 15,30 | 902  | 908 | 911 | 946  | 1008 |
|   |   |   | High  | M-L                                     | AT0303                              | 15,60 | 911  | 916 | 920 | 955  | 1016 |
|   |   | RAL 9005  | Medium  | M-L                                     | AT0319                              | 13,00 | 772  | 778 | 783 | 817  | 879  |
|   |   |   | High  | M-L                                     | AT0320                              | 13,30 | 783  | 788 | 791 | 825  | 886  |
|   |   | RAL 9005  | Medium  | M-L                                     | AT0321                              | 13,00 | 779  | 785 | 790 | 824  | 886  |
|   |   |   | High  | M-L                                     | AT0322                              | 13,30 | 790  | 795 | 798 | 832  | 893  |

\* DISPONIBILE ANCHE IN  
 ALSO AVAILABLE  
 ÉGALEMENT DISPONIBLE EN  
 ERHÄLTICH AUCH IN  
 TAMBIÉN DISPONIBLE EN













| BASE<br>BASE<br>PIETEMET<br>GESTELL<br>BASE | RUOTA/PIEDINO<br>CASTOR/FEET<br>ROULETTES/PATINS<br>RÖLLEN/GLEITER<br>RUEDAS/PIES | STRUTTURA<br>STRUCTURE<br>STRUCTURE<br>STRUKTUR<br>ESTRUCTURA | SCHIENALE<br>BACKREST<br>DOSSIER<br>RÜCKENLEHNE<br>RESPALDO | RETE<br>MESH<br>MAILLE<br>NETZ<br>MALLA | CODICE<br>CODE<br>ARTIKEL<br>CÓDIGO | KG    | TESSUTI/FINITURE<br>UPHOLSTERIES/FINISHING<br>REVETEMENTS<br>STOFFGRUPPE<br>TAPICERÍAS |      |      |      |      |
|---|---|---|---|---|-------------------------------------|-------|--|------|------|------|------|
|   |   |   |   |   |                                     |       | D  | E    | F    | G    | H    |
|   |   | Chromed   | Medium  | M-L                                     | AT0206                              | 17,70 | 1129   | 1137 | 1141 | 1175 | 1236 |
|   |   |   | High  | M-L                                     | AT0008                              | 18,00 | 1147   | 1152 | 1155 | 1188 | 1250 |
|   |   | RAL 9005  | Medium  | M-L                                     | AT0304                              | 17,70 | 1129   | 1137 | 1141 | 1175 | 1236 |
|   |   |   | High  | M-L                                     | AT0305                              | 18,00 | 1147   | 1152 | 1155 | 1188 | 1250 |
|   |   | Chromed   | Medium  | M-L                                     | AT0210                              | 19,30 | 1252   | 1261 | 1267 | 1298 | 1360 |
|   |   |   | High  | M-L                                     | AT0012                              | 19,60 | 1270   | 1275 | 1279 | 1313 | 1374 |
|   |   | RAL 9005  | Medium  | M-L                                     | AT0306                              | 19,30 | 1195   | 1204 | 1210 | 1241 | 1303 |
|   |   |   | High  | M-L                                     | AT0307                              | 19,60 | 1213   | 1218 | 1222 | 1256 | 1317 |

\* DISPONIBILE ANCHE IN  
 ALSO AVAILABLE  
 ÉGALEMENT DISPONIBLE EN  
 ERHÄLTICH AUCH IN  
 TAMBIÉN DISPONIBLE EN



# ATTIVA

## OPTIONALS

| OPZIONE<br>OPTIONALS<br>OPTIONS<br>OPTIONEN<br>OPCIONES                               | VARIANTE<br>VARIANT<br>VARIANTE<br>VARIANTE<br>VARIANTE                                      | CODICE<br>CODE<br>CODE<br>ARTIKEL<br>CÓDIGO | KG   | PREZZO<br>PRICE<br>PRIX<br>PREIS<br>PRECIO | TESSUTI/FINITURE<br>UPHOLSTERIES/FINISHING<br>REVETEMENTS<br>STOFFGRUPPE<br>TAPICERÍAS |     |     |     |     |
|---|--|---|------|--|--|-----|-----|-----|-----|
|   |  |   |      |  | D  | E   | F   | G   | H   |
|      | Chromed  | <b>XB001</b>                                | 2,00 | 187  |  |     |     |     |     |
|   | *  RAL 9005 | <b>XB105</b>                                | 2,00 | 187  |  |     |     |     |     |
|      | Chromed  | <b>XB002</b>                                | 2,20 |  | 205  | 205 | 205 | 205 | 205 |
|   | *  RAL 9005 | <b>XB102</b>                                | 2,20 |  | 205  | 205 | 205 | 205 | 205 |
|      | <b>3D</b>  | <b>XB092</b>                                | 2,50 | 107  |  |     |     |     |     |
|     | <b>3D SOFT</b>   | <b>XB087</b>                                | 2,50 | 145  |  |     |     |     |     |
| *  | <b>4D EXTRASOFT</b>  | <b>XB089</b>                                | 2,60 | 102  |  |     |     |     |     |
|    | <b>4D EXTRASOFT</b>  | <b>XB090</b>                                | 2,60 | 161  |  |     |     |     |     |
|    | <b>MEDIUM</b>  | <b>XC013</b>                                | 0,50 |  | 82   | 88  | 95  | 142 | 204 |
|    | <b>HIGH</b>  | <b>XC012</b>                                | 1,00 |  | 87   | 96  | 104 | 161 | 246 |

\* DISPONIBILE ANCHE IN  
ALSO AVAILABLE  
ÉGALEMENT DISPONIBLE EN  
ERHÄLTlich AUCH IN  
TAMBIÉN DISPONIBLE EN



RAL 9016



RAL 6021



RAL 1012



RAL 7032









RAL 3012

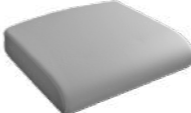

RAL 7046

# ATTIVA

## OPTIONALS

| OPZIONE<br>OPTIONALS<br>OPTIONS<br>OPTIONEN<br>OPCIONES                               | VARIANTE<br>VARIANT<br>VARIANTE<br>VARIANTE<br>VARIANTE   | CODICE<br>CODE<br>CODE<br>ARTIKEL<br>CÓDIGO | KG   | PREZZO<br>PRICE<br>PRIX<br>PREIS<br>PRECIO | TESSUTI/FINITURE<br>UPHOLSTERIES/FINISHING<br>REVETEMENTS<br>STOFFGRUPPE<br>TAPICERÍAS |     |     |     |     |
|---|---|---|------|--|--|-----|-----|-----|-----|
|   |   |   |      |  | D  | E   | F   | G   | H   |
|    | <b>MEDIUM</b>   | <b>XC021</b>                                | 1,00 |  | 205  | 211 | 218 | 237 | 383 |
|    | <b>HIGH</b>   | <b>XC020</b>                                | 1,00 |  | 211  | 219 | 229 | 252 | 399 |
|    | Poggiatesta<br>Headrest<br>Appui-tête<br>Kopfstütze<br>Reposacabezas  | <b>XT001</b>                                | 0,80 |  | 173  | 173 | 173 | 173 | 173 |
|    | Sedile Comfort<br>Comfort Seats<br>Assise Confort<br>Komfort Sitz<br>Asiento Confortable                                | <b>XD018</b>                                | 0,60 | 25   |  |     |     |     |     |
|  | SEAT WITH<br>NEGATIVE INCLINATION<br>ONLY FOR <b>SynchroPlus</b><br><small>TECH INSIDE. SIMPLE OUTSIDE</small>          | <b>XM007</b>                                | 1,30 | 35   |  |     |     |     |     |
|  | Supporto lombare nero<br>Black lumbar support<br>Soutien lombaire noir<br>Schwarze Lumbalstütze<br>Soporte lombar negro | <b>XR006</b>                                | 0,30 | 35   |  |     |     |     |     |
|  | Small<br>Desk Pad<br>50x35 cm   | <b>XA020</b>                                | 2,30 |  |  |     |     | 130 |     |
|  | Large<br>Desk Pad<br>80x50 cm   | <b>XA021</b>                                | 5,30 |  |  |     |     | 246 |     |

\* DISPONIBILE ANCHE CON  
ALSO AVAILABLE WITH  
ÉGALEMENT DISPONIBLE AVEC  
ERHÄLTlich AUCH MIT  
TAMBIÉN DISPONIBLE CON



d.65 mm gommate forate  
self-braking d.65 mm perforated  
d.65 mm outofreinante perforé  
gebremste Rollen Design D.65 mm  
diam.65 autofreno perforado

**+100€**

# CRONO

idea: *Pietro Lovato*



## 1. SCHIENALE:

Schienale in tubo d'acciaio con molle greche in spugna schiumata a freddo, regolabile in altezza (6 cm)

## 2. SEDILE:

Sedile in polipropilene imbottito con spugna schiumata a freddo, rivestito. Molle sedile: di serie su SynchroTek, opzionale su SynchroPlus

## 3. MECCANISMO:

- SynchroPlus+, comando elevazione a gas, regolazione tensione schienale, inclinazione 20°sch. 8°sed. in 5 posizioni con antishock, traslazione sed. 6cm in 5 posizioni.
- SynchroTeK cromato o nero, comando elevazione a gas, regolazione tensione schienale: inclinazione 26°sch. 10.5°sed. in 5 posizioni con antishock, inclinazione negativa sed. 4,5° traslazione sed. 6cm in 5 posizioni

## 4. GAS:

- Regolabile in altezza, rotazione, finitura cromata
- Regolabile in altezza, rotazione, finitura nera
- Regolabile in altezza, rotazione, finitura cromata, molleggio

## 5. BASE:

- 5 razze in alluminio, Ø 710mm, finitura lucida.
- Base 5 razze in poliamide con carica di fibra di vetro, Ø 680mm, finitura nero

## 6. RUOTE:

- Ø 65mm, gommate o autofrenanti e gommate, finitura nera.
- Ø 50mm, autofrenanti o autofrenanti e gommate, finitura nera

## 1. BACKREST:

Steel tube backrest with zigzag springs in cold injected foam, height adjustable (6cm)

## 2. SEAT:

Seat in polypropylene padded with cold injected foam, upholstered. Seat springs: default on SynchroTek, optional on SynchroPlus

## 3. MECHANISM:

- Chromed or black SynchroTek, gas lift height adj. Backrest tension adj. Backrest inclination: 26° in 5 positions with antishock; Seat inclination: 10.5°. Negative seat inclination: 4.5°. Sliding seat device 6cm in 5 positions
- SynchroPlus+, gas lift height adj. Backrest tension adj. Backrest inclination 20° in 5 locking position with antishock, seat inclination 8°. Sliding seat device 6cm in 5 positions

## 4. GAS LIFT:

- Height adjustable, swivel, chromed finish
- Height adjustable, swivel, Black finish
- Height adjustable, swivel, chromed finish, shock absorber springs

## 5. BASE:

- Polished aluminium 5 spoke base, Ø 710 mm
- Fiberglass reinforced polyamide 5 spoke base, Ø 680 mm, black finish

## 6. CASTORS:

- Ø 65mm self-braking castors, or soft self-braking. Black finish
- Ø 50 mm self-braking castors, or soft self-braking. Black finish

## 1. DOSSIER:

Dossier en tube d'acier avec ressorts et mousse moulée à froids, réglable en hauteur (6 cm)

## 2. ASSISE:

Assise en polypropylène rembourrée de mousse moulée à froids, tapissée. Ressorts assise: d'office sur SynchroTek, option sur SynchroPlus

## 3. MECANISME:

- SynchroTeK chromé ou noir, réglage en hauteur, réglage de tension, inclinaison dossier 26°et assise 10,5°, en 5 positions avec système antichoc, inclinaison négative assise 4,5°, profondeur d'assise 6 cm en 5 positions
- SynchroPlus+, réglage en hauteur, réglage de tension, inclinaison dossier 20°et assise 8°, en 5 positions avec système anti-choc, profondeur d'assise 6 cm en 5 positions

## 4. VERIN A GAZ:

- Réglable en hauteur, pivotant, finition chromé
- Réglable en hauteur, pivotant, finition noir
- Réglable en hauteur, pivotant, finition chromé, amortisseur

## 5. PIÈTEMENT:

- Piètement 5 branches alu poli, Ø 710mm
- Piètement 5 branches en polyamide renforcé en fibre de verre, Ø 680mm, finition noir

## 6. ROULETTES:

- Roulettes Ø 65mm, gommées ou autofreinantes et gommées, finition noir
- Roulettes Ø 50mm, autofreinantes ou autofreinantes et gommées, finition noir

## 1. RÜCKENLEHNE:

Höhenverstellbare Rückenlehne (6cm), Stahlrohrrahmen mit Nosagfedern, ausgepolstert mit kaltgeschäumten Polyurethan

## 2. SITZ:

Polypropylen-Sitz, ausgepolstert mit kaltgeschäumten Polyurethan, mit Überzug. Sitz-Federkerntaschen: standard mit Synchrotek-Mechanik, optional mit SynchroPlus-Mechanik.

## 3. MECHANIK:

- SynchroTeK verchromt oder schwarz, Gaslift Höhenverstellung, Rückenlehne mit Spannungsregler, 26°Rückenlehneigung, 10,5°Sitzneigung, negative Sitzneigung 4,5°, 5-stufige Einstellung mit Antishock, 6 cm Sitztiefenverstellung mit 5 Positionen
- SynchroPlus+, Gaslift Höhenverstellung, Rückenlehne mit Spannungsregler, 20°Rückenlehneigung, 8°Sitzneigung, 5-stufige Einstellung mit Antishock, 6 cm Sitztiefenverstellung mit 5 Positionen

## 4. GASFEDER:

- Sitzhöhenverstellung, drehbar, verchromt
- Sitzhöhenverstellung, drehbar, schwarz
- Sitzhöhenverstellung, drehbar, verchromt, mit Stoßdämpfende Feder

## 5. GESTELL:

- 5-Stern Alu poliertes Fußkreuz, Ø 710 mm
- 5-Stern schwarzes glasfaserverstärktes Polyamid Fußkreuz, Ø 680 mm

## 6. ROLLEN:

- Ø 65 mm gebremste, oder weiche gebremste Rollen, schwarze
- Ø 50 mm gebremste, oder weiche gebremste Rollen, schwarz

## 1. RESPALDO:

Respaldo de tubo de acero con resortes zig-zag en espuma inyectada a frío, ajustable en altura (6 cm)

## 2. ASIENTO:

Asiento en polipropileno acolchado con espuma inyectada a frío, tapizado. Resortes del asiento: de serie en SynchroTek, opcional en SynchroPlus

## 3. MECANISMO:

- SynchroPlus+, control de elevación de gas, ajuste de tensión posterior, inclinación respaldo 20° . 8° asiento En 5 posiciones con antishock, desplazamiento asiento 6cm en 5 posiciones.
- SynchroTeK cromado o negro, control de elevación de gas, ajuste de la tensión de respaldo: inclinación de 26° resp. 10.5° asiento. en 5 posiciones con antishock, inclinación negativa asiento. 4.5° desplazamiento asiento. 6cm en 5 posiciones

## 4. GAS:

- Ajustable en altura, rotación, acabado cromado.
- Ajustable en altura, rotación, acabado negro.
- Ajustable en altura, rotación, acabado cromado, resorte.

## 5. BASE:

- 5 rayos en aluminio, Ø 710mm, acabado brillante.
- Base de 5 rayos en poliamida con carga de fibra de vidrio, Ø 680 mm, acabado negro

## 6. RUEDAS:

- Ø 65mm, blandas o autofrenado y blandas, acabado negro.
- Ø 50 mm, blandas o autofrenado y blandas, acabado negro.



ID 1111209675

# CRONO



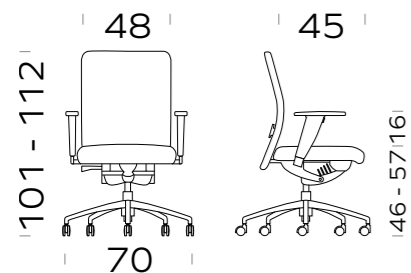

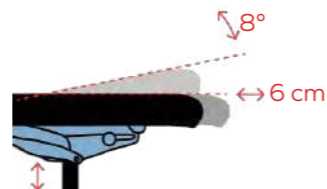

IMBOTTITA, SCHIENALE MEDIO REGOLABILE IN ALTEZZA, SUPPORTO LOMBARE  
 UPHOLSTERED, ADJUSTABLE MEDIUM BACKREST, LUMBAR SUPPORT  
 REMBOURRÉ, DOSSIER MOYEN RÉGLABLE EN HATEUR, SOUTIEN LOMBAIRE  
 GEPOLSTERT, HÖHENVERSTELLUNG MITTLERE RÜCKENLEHNE, LUMBALSTÜTZE  
 TAPIZADA, MEDIO RESPALDO REGLABLE, SUPORTE LUMBAR



Mechanism: **SynchroPlus**  
 TECH INSIDE, SIMPLE OUTSIDE  
 Slide →



Blocco oscillante, Regolazione altezza/tensione, Regolazione in profondità del sedile  
 (Un-)locking device, Height/tension adjustment, Depth adjustment of the seat  
 Système de blocage-déblocage de l'oscillation, Réglage en hauteur/ d'intensité, Réglage en profondeur de l'assise  
 Blockierung der Rückenlehne / Spannungsregler / Höhenverstellung, Sitztiefenverstellung  
 Sistema de bloqueo-desbloqueo del respaldo, Ajuste de altura/tensión, Ajuste de profundidad del asiento

| BASE<br>BASE<br>PIETEMENT<br>GESTELL<br>BASE   | RUOTA/PIEDINO<br>CASTOR/FEET<br>ROULETTES/PATINS<br>ROLLEN/GLEITER<br>RUEDAS/PIES  | STRUTTURA<br>STRUCTURE<br>STRUCTURE<br>STRUKTUR<br>ESTRUCTURA   | CODICE<br>CODE<br>ARTIKEL<br>CÓDIGO | KG    | TESSUTI/FINITURE<br>UPHOLSTERIES/FINISHING<br>REVÊTEMENTS<br>STOFFGRUPPE<br>TAPICERIAS |     |     |     |      |
|--|--|---|-------------------------------------|-------|--|-----|-----|-----|------|
|  |  |   |                                     |       | D  | E   | F   | G   | H    |
| <br>5 razze poliammide<br>5-spoke polyamide<br>5-branches polyamide<br>5-Stern Polyamid Fußkreuz<br>estrella en polyamida |  *<br>d.50mm autofrenanti gomme<br>soft self-braking d.50mm<br>d.50 mm gommées autofreinante<br>weiche gebremste D.50 mm<br>ruedas goma diam.50 autofreno | <br>RAL 9005<br>*  | <b>CR0021</b>                       | 15,40 | 643  | 664 | 683 | 822 |      |
| <br>5 razze in alluminio<br>5-spoke aluminium<br>5 branches alu<br>5-Stern Alu Fußkreuz<br>estrella en aluminio         | <br>d.65 gomme<br>soft d.65 mm<br>d.65mm gommées<br>weiche D.65 mm<br>ruedas goma diam.65   | <br>Chromed<br><br><br>RAL 9005<br>* | <b>CR0026</b>                       | 16,60 | 753  | 779 | 805 | 936 | 1194 |
|  |  |   | <b>CR0148</b>                       | 16,60 | 753  | 779 | 805 | 936 | 1194 |

\* DISPONIBILE ANCHE IN  
 ALSO AVAILABLE  
 ÉGALEMENT DISPONIBLE EN  
 ERHÄLTlich AUCH IN  
 TAMBIÉN DISPONIBLE EN



RAL 9016



RAL 6021



RAL 1012



RAL 7032



RAL 3012



RAL 7046

\* DISPONIBILE ANCHE CON  
 ALSO AVAILABLE WITH  
 ÉGALEMENT DISPONIBLE AVEC  
 ERHÄLTlich AUCH MIT  
 TAMBIÉN DISPONIBLE CON



d.50 mm autofrenanti  
 self-braking d.50mm  
 d.50mm autofreinante  
 gebremste D.50mm  
 diam.50 autofreno

**SAME PRICE**

# CRONO



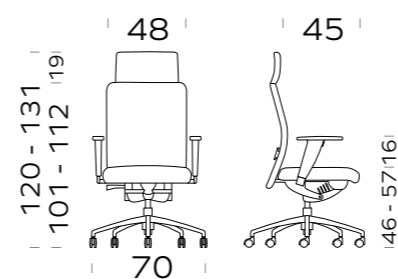

IMBOTTITA, SCHIENALE MEDIO REGOLABILE IN ALTEZZA, SUPPORTO LOMBARE  
 UPHOLSTERED, ADJUSTABLE MEDIUM BACKREST, LUMBAR SUPPORT  
 REMBOURRÉ, DOSSIER MOYEN RÉGLABLE EN HATEUR, SOUTIEN LOMBAIRE  
 GEPOLSTERT, HÖHENVERSTELLUNG MITTLERE RÜCKENLEHNE, LUMBALSTÜTZE  
 TAPIZADA, MEDIO RESPALDO REGLABLE, SUPORTE LUMBAR

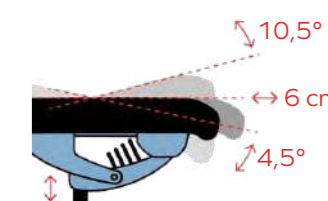

Mechanism: **SynchroTek**  
 Slide ← Neg ↓



Blocco oscillante, Regolazione altezza/tensione, Regolazione in profondità del sedile, Inclinazione negativa  
 (Un-)locking device, Height/tension adjustment, Depth adjustment of the seat, Negative inclination  
 Système de blocage-déblocage de l'oscillation, Réglage en hauteur/ d'intensité, Réglage en profondeur de l'assise, Inclinaison négative  
 Blockierung der Rückenlehne / Spannungsregler / Höhenverstellung, Sitztiefenverstellung, Sitzneigungsverstellung  
 Sistema de bloqueo-desbloqueo del respaldo, Ajuste de altura/tensión, Ajuste de profundidad del asiento, Inclinación negativa

| BASE<br>BASE<br>PIETEMENT<br>GESTELL<br>BASE   | RUOTA/PIEDINO<br>CASTOR/FEET<br>ROULETTES/PATINS<br>ROLLEN/GLEITER<br>RUEDAS/PIES  | STRUTTURA<br>STRUCTURE<br>STRUCTURE<br>STRUKTUR<br>ESTRUCTURA  | CODICE<br>CODE<br>ARTIKEL<br>CÓDIGO | KG    | TESSUTI/FINITURE<br>UPHOLSTERIES/FINISHING<br>REVÊTEMENTS<br>STOFFGRUPPE<br>TAPICERIAS |      |      |      |      |
|--|--|--|-------------------------------------|-------|--|------|------|------|------|
|  |  |  |                                     |       | D  | E    | F    | G    | H    |
| <br>5 razze in alluminio<br>5-spoke aluminium<br>5-branches alu<br>5-Stern Alu Fußkreuz<br>estrella en aluminio | <br>d.65 gomme<br>soft d.65 mm<br>d.65mm gommées<br>weiche D.65 mm<br>ruedas goma diam.65 | <br>Chromed       | <b>CR0040</b>                       | 20,50 | 1120   | 1139 | 1158 | 1297 | 1557 |
|  |  | <br>RAL 9005<br>* | <b>CR0149</b>                       | 20,50 | 1120   | 1139 | 1158 | 1297 | 1557 |

\* DISPONIBILE ANCHE IN  
 ALSO AVAILABLE  
 ÉGALEMENT DISPONIBLE EN  
 ERHÄLTlich AUCH IN  
 TAMBIÉN DISPONIBLE EN



RAL 9016



RAL 6021



RAL 1012



RAL 7032













RAL 3012

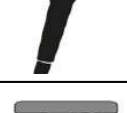

RAL 7046

# CRONO **OPTIONALS**

| OPZIONE<br>OPTIONALS<br>OPTIONS<br>OPTIONEN<br>OPCIONES                               | VARIANTE<br>VARIANT<br>VARIANTE<br>VARIANTE<br>VARIANTE                             | CODICE<br>CODE<br>CODE<br>ARTIKEL<br>CODIGO | KG   | PREZZO<br>PRICE<br>PRIX<br>PREIS<br>PRECIO | TESSUTI/FINITURE<br>UPHOLSTERIES/FINISHING<br>REVETEMENTS<br>STOFFGRUPPE<br>TAPICERIAS |     |     |     |     |
|---|---|---|------|--|--|-----|-----|-----|-----|
|   |   |   |      |  | D  | E   | F   | G   | H   |
|      | Chromed   | <b>XB001</b>                                | 2,00 | 187  |  |     |     |     |     |
|   | *  | <b>XB105</b>                                | 2,00 | 187  |  |     |     |     |     |
|      | Chromed   | <b>XB002</b>                                | 2,20 |  | 205  | 205 | 205 | 205 | 205 |
|   | *  | <b>XB102</b>                                | 2,20 |  | 205  | 205 | 205 | 205 | 205 |
|      | <b>2D</b>   | <b>XB018</b>                                | 2,50 | 81   |  |     |     |     |     |
|      | <b>2D SOFT</b>  | <b>XB025</b>                                | 2,60 | 113  |  |     |     |     |     |
| *   | <b>2D</b>   | <b>XB020</b>                                | 1,30 | 39   |  |     |     |     |     |
| *  | <b>2D SOFT</b>  | <b>XB022</b>                                | 1,60 | 61   |  |     |     |     |     |
|    | <b>3D</b>   | <b>XB092</b>                                | 2,50 | 107  |  |     |     |     |     |
|    | <b>3D SOFT</b>  | <b>XB087</b>                                | 2,50 | 145  |  |     |     |     |     |
| *  | <b>3D</b>   | <b>XB021</b>                                | 1,30 | 71   |  |     |     |     |     |

\* DISPONIBILE ANCHE IN  
ALSO AVAILABLE  
ÉGALEMENT DISPONIBLE EN  
ERHÄLTlich AUCh IN  
TAMBIÉN DISPONIBLE EN



RAL 9016



RAL 6021



RAL 1012



RAL 7032







RAL 3012

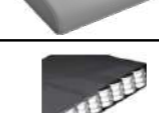
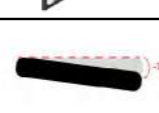
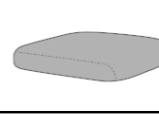
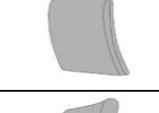

RAL 7046

# CRONO **OPTIONALS**

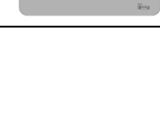
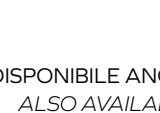
| OPZIONE<br>OPTIONALS<br>OPTIONS<br>OPTIONEN<br>OPCIONES                               | VARIANTE<br>VARIANT<br>VARIANTE<br>VARIANTE<br>VARIANTE   | CODICE<br>CODE<br>CODE<br>ARTIKEL<br>CODIGO | KG   | PREZZO<br>PRICE<br>PRIX<br>PREIS<br>PRECIO | TESSUTI/FINITURE<br>UPHOLSTERIES/FINISHING<br>REVETEMENTS<br>STOFFGRUPPE<br>TAPICERIAS |     |     |     |     |
|---|---|---|------|--|--|-----|-----|-----|-----|
|   |   |   |      |  | D  | E   | F   | G   | H   |
| *  | <b>3D SOFT</b>  | <b>XB023</b>                                | 1,60 | 92   |  |     |     |     |     |
| *  | <b>4D EXTRASOFT</b>   | <b>XB089</b>                                | 2,60 | 102  |  |     |     |     |     |
|    | <b>4D EXTRASOFT</b>   | <b>XB090</b>                                | 2,60 | 161  |  |     |     |     |     |
|    | Sedile Comfort<br>Comfort Seats<br>Assise Comfort<br>Komfort Sitz<br>Asiento Confortable  | <b>XD018</b>                                | 0,60 | 25   |  |     |     |     |     |
|   | Molle sedile<br>Seat springs<br>Ressorts assise<br>Sitz Federkern<br>Resortes asientos  | <b>XD001</b>                                | 0,80 | 37   |  |     |     |     |     |
|  | SEAT WITH<br>NEGATIVE INCLINATION<br>ONLY FOR <b>SynchroPlus</b>  | <b>XM007</b>                                | 1,30 | 35   |  |     |     |     |     |
|  | Coprisedile removibile<br>Removable seat cover<br>Housse assise, amovible<br>Sitzbezug, abnehmbar<br>Funda para asiento retirable | <b>FOD180</b>                               |      |  | 36   | 40  | 48  |     |     |
|  | Poggiatesta<br>Headrest<br>Appui-tête<br>Kopfstütze<br>Reposacabezas  | <b>XT002</b>                                | 0,80 |  | 113  | 119 | 119 | 132 | 158 |
|  | Poggiatesta regolabile<br>Adjustable headrest<br>Appui-tête réglable<br>Verstellbare Kopfstütze<br>Reposacabezas ajustable        | <b>XT015</b>                                | 0,80 |  | 140  | 145 | 145 | 158 | 186 |
|  | Small<br>Desk Pad<br>50x35 cm   | <b>XA020</b>                                | 2,30 |  |  |     |     | 130 |     |
|  | Large<br>Desk Pad<br>80x50 cm   | <b>XA021</b>                                | 5,30 |  |  |     |     |     | 246 |

\* DISPONIBILE ANCHE IN  
ALSO AVAILABLE  
ÉGALEMENT DISPONIBLE EN  
ERHÄLTlich AUCh IN  
TAMBIÉN DISPONIBLE EN



RAL 9016



RAL 6021



RAL 1012



RAL 7032



RAL 3012



RAL 7046

CRONO  
idea: *Pietro Lovato*



**1. POGGIATESTA:**  
Imbottito con spugna in poliuretano espanso indeformabile schiumato a freddo

**2. SCHIENALE:**  
Alto regolabile in altezza e regolatore lombare. Con struttura portante in tubo tondo d'acciaio, Ø 20 mm, rivestita in tessuto e molle greche. Imbottito con spugna in poliuretano espanso che lo rende indeformabile, schiumato a freddo, ignifugo secondo la norma UNI EN 0175

**3. SEDILE:**  
Polipropilene caricato fibra di vetro con una spugna in poliuretano espanso indeformabile schiumato a freddo con all'interno 64 molle imbustate singolarmente per impedire lo sfregamento e renderle silenziose

**4. MECCANISMO:**  
SynchroTek nero che consente l'inclinazione di 26° dello schienale e di 10,5° del sedile con regolazione dell'intensità della forza sullo schienale per adattarsi a persone di peso differenti; bloccaggio dello schienale in almeno 5 posizioni con sistema antishock grazie alla traslazione del sedile di 6 cm, inclinazione negativa di 4,5° ed elevazione a gas

**5. GAS:**  
Regolabile in altezza, rotazione, finitura cromata, molleggio

**6. BASE:**  
5 razze presso fusa in alluminio con finitura lucida

**7. RUOTE:**  
Gommate auto frenanti Ø 50 mm. La sfera di rotazione in acciaio temperato presente all'interno delle ruote, facilita la rotazione e previene la possibilità di usura della sede del perno. In fase di montaggio inoltre su ogni ruota viene eseguito una speciale trattamento per eliminare eventuali rumori durante il movimento

**8. BRACCIOLI:**  
Regolabili 3D cromati con top morbido

**1. HEADREST:**  
Upholstered padded with non-deformable polyurethane foam, cold foamed

**2. BACKREST:**  
Height adjustable with lumbar support. Structure made of round steel tube, Ø 20 mm with metal springs. Polyurethane cold foam, non-deformable, fireproof according to the UNI EN 0175 standard, covered with fabric

**3. SEAT:**  
Made of glass fiber reinforced polypropylene with a non-deformable polyurethane cold foam, inside 64 individually wrapped springs to prevent rubbing and make them silent

**4. SYNCHRONOUS MECHANISM:**  
SynchroTek black that allows the inclination of 26° of the backrest and 10.5° of the seat with weight adjustment to adapt to people of different weights; lockable in 5 positions with anti-shock system, 6 cm sliding seat, seat tilt 4.5° and gas lift

**5. GAS LIFT:**  
Height adjustable, swivel, chromed finish, shock absorber springs

**6. BASE:**  
5-star polished aluminum

**7. CASTORS:**  
Self-braking Ø 50 mm. The fixing pin is rotating inside on a metal ball of hardened steel, giving a long lasting usage. In the assembly phase each wheel gets a special treatment to eliminate any noise during movement

**8. ARMREST:**  
3D, with soft pad

**1. APPUI-TÊTE:**  
Rembourré en mousse de polyuréthane indéformable, moussé à froid

**2. DOSSIER:**  
Réglable en hauteur et lombaire. Avec structure portante en tube d'acier rond, Ø 20 mm recouvert de tissu et de sources grecques. Rembourré avec une éponge en mousse de polyuréthane qui le rend indéformable, mousse résistante au froid et au feu selon la norme UNI EN 0175.

**3. ASSISE:**  
Polypropylène chargé de fibres de verre et mousse de polyuréthane indéformable, moussé à froid à l'intérieur de 64 ressorts emballés individuellement pour éviter les frottements et les rendre silencieux.

**4. MECANISME:**  
SynchroTek noir qui permet l'inclinaison de 26° du dossier et de 10,5° de l'assise avec un ajustement de l'intensité de la force sur le dos pour s'adapter aux personnes de poids différents; verrouillage du dossier dans au moins 5 positions avec système anti-choc grâce au système de décalage du siège de 6 cm, à une inclinaison négative de 4,5° et à l'élévation du gaz.

**5. VERIN A GAZ:**  
Réglable en hauteur, pivotant, finition chromé, amortisseur.

**6. PIÈTEMENT:**  
5 branches alu poli.

**7. ROULETTES:**  
Auto-freinant Ø 50 mm. La sphère de rotation en acier trempé à l'intérieur des roues, facilite la rotation et empêche l'usure du siège de la broche. Dans la phase de montage vient aussi sur chaque roue effectué un traitement spécial pour éliminer tout bruit pendant le mouvement.

**8. ACCOUDOIR:**  
Réglables 3D chromés manchette souple.

**1. GEPOLSTERTE:**  
Kopfstütze mit kalt geschäumtem Polyurethanschaum.

**2. RÜCKENLEHNE:**  
Höheneinstellbar, mit Lendenwirbelstütze. Konstruktion aus Rundstahlrohr, Ø 20 mm, Metallfedern. Polyurethanschaum kaltgeschäumt, feuerfest nach der Norm UNI EN 0175, gepolstert mit Stoff.

**3. SITZ:**  
Aus glasfaserverstärktem Polypropylen mit Polyurethanschaum, kalt geschäumt. Innen mit Federkern aus 64 einzeln umwickelten Federn, speziell behandelt um Abrieb und Geräusche zu vermeiden.

**4. SYNCHRONMECHANIK:**  
SynchroTek schwarz, Neigung Rückenlehne bis 26° und Sitz bis 10,5°, mit Federkraftregulierung für unterschiedliche Nutzer; Arretierung der Rückenlehne in 5 Positionen mit Anti-Schock-System, 6 cm Schiebesitz, Sitzneigung 4,5°, Gasfeder mit mechanischer Tiefenfederung.

**5. GASFEDER:**  
Sitzhöhenverstellung, drehbar, verchromt, mit Stoßdämpfende Feder.

**6. FUSSKREUZ:**  
5-Stern Alu poliert.

**7. ROLLEN:**  
Gebremst, D 50mm, weich mit verchromter Abdeckung. Der Befestigungsstift ist kugelgelagert für eine lange Nutzung. In der Montage erhält jede Rolle eine spezielle Behandlung um Geräusche während der Bewegung zu verhindern.

**8. ARMLEHNE:**  
3D, mit weicher Armauflage.

**1. REPOSACABEZAS:**  
Acolchada con espuma de poliuretano no deformable, espuma inyectada a frío.

**2. RESPALDO:**  
Alto regulable en altura y regulador lumbar. Con estructura de soporte en tubo de acero redondo, Ø 20 mm. Cubierto en tela y muelles griegos. Rellena con una esponja de espuma inyectada a frío de poliuretano que la hace no deformable, con espuma Frío, incombustible según la norma UNI EN 0175.

**3. ASIENTO:**  
Polipropileno relleno de fibra de vidrio con espuma de poliuretano no deformable, espuma fría dentro de 64 resortes envueltos individualmente para evitar el roce y silenciarlos.

**4. MECANISMO:**  
SynchroTek negro que permite la inclinación de 26° del respaldo y 10,5° del asiento con ajuste de la intensidad de la fuerza en la espalda para adaptarse a personas de diferentes pesos; Bloqueo del respaldo en al menos 5 posiciones con sistema antichoque gracias al desplazador de asiento de 6 cm, inclinación negativa de 4,5° y elevación de gas.

**5. GAS:**  
Ajustable en altura, rotación, acabado cromado, muelle.

**6. BASE:**  
Estrella en alum. pulido.

**7. RUEDAS:**  
Goma autofreno diam. Ø 50 mm. La esfera de rotación en acero endurecido dentro de las ruedas, facilita la rotación y evita el desgaste del asiento del pasador. En la fase de montaje también en cada rueda recibe. Realiza un tratamiento especial para eliminar cualquier ruido durante el movimiento.

**8. BRAZOS:**  
Reglable 3D cromo y top suave.

## TECHNICAL INFORMATION



ID 1111209675

# CRONO24

IMBOTTITA, SCHIENALE MEDIO REGOLABILE IN ALTEZZA, SUPPORTO LOMBARE  
 UPHOLSTERED, ADJUSTABLE MEDIUM BACKREST, LUMBAR SUPPORT  
 REMBOURRÉ, DOSSIER MOYEN RÉGLABLE EN HAUTEUR, SOUTIEN LOMBAIRE  
 GEPOLSTERT, HÖHENVERSTELLUNG MITTLERE RÜCKENLEHNE, LUMBALSTÜTZE  
 TAPIZADA, MEDIO RESPALDO REGLABLE, SUPORTE LUMBAR

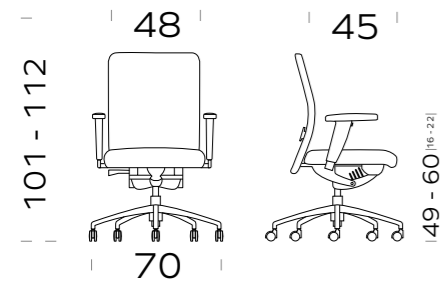

Mechanism: **SynchroTek**  
 Slide Neg ↓

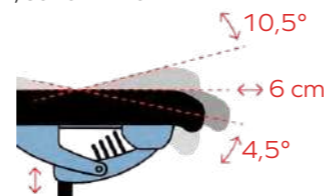

Blocco oscillante, Regolazione altezza/tensione, Regolazione in profondità del sedile, Inclinazione negativa  
 (Un-)locking device, Height/tension adjustment, Depth adjustment of the seat, Negative inclination  
 Système de blocage-déblocage de l'oscillation, Réglage en hauteur/ d'intensité, Réglage en profondeur de l'assise, Inclinaison négative  
 Blockierung der Rückenlehne /Spannungsregler / Höhenverstellung, Sitztiefenverstellung, Sitzneigungsverstellung  
 Sistema de bloqueo-desbloqueo del respaldo, Ajuste de altura/tensión, Ajuste de profundidad del asiento, Inclinación negativa

| BASE<br>BASE<br>PIETEMENT<br>GESTELL<br>BASE | RUOTA/PIEDINO<br>CASTOR/FEET<br>ROULETTES/PATINS<br>ROLLEN/GLEITER<br>RUEDAS/PIES | STRUTTURA<br>STRUCTURE<br>STRUCTURE<br>STRUKTUR<br>ESTRUCTURA | CODICE<br>CODE<br>CODE<br>ARTIKEL<br>CÓDIGO | KG    | TESSUTI/FINITURE<br>UPHOLSTERIES/FINISHING<br>REVÊTEMENTS<br>STOFFGRUPPE<br>TAPICERÍAS |
|--|---|---|---|-------|--|
|  |   |   |   |       | G  |
|  |   |   | <b>CR0125</b>                               | 20,50 | 1424   |
|  |   |   | <b>CR0150</b>                               | 20,50 | 1424   |

\* DISPONIBILE ANCHE IN  
 ALSO AVAILABLE  
 ÉGALEMENT DISPONIBLE EN  
 ERHÄLTLICH AUCH IN  
 TAMBIÉN DISPONIBLE EN



RAL 9016



RAL 1012



RAL 3012



RAL 6021



RAL 7032



RAL 7046

# CRONO24

## OPTIONALS

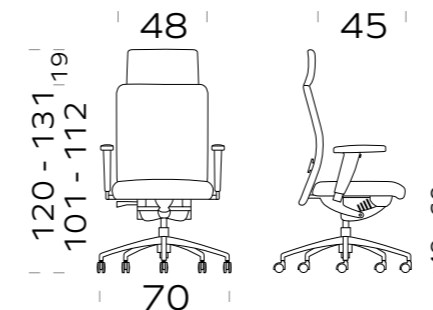

| OPZIONE<br>OPTIONALS<br>OPTIONS<br>OPTIONEN<br>OPCIONES | VARIANTE<br>VARIANT<br>VARIANTE<br>VARIANTE<br>VARIANTE  | CODICE<br>CODE<br>CODE<br>ARTIKEL<br>CÓDIGO | KG   | PREZZO<br>PRICE<br>PRIX<br>PREIS<br>PRECIO | TESSUTI/FINITURE<br>UPHOLSTERIES/FINISHING<br>REVÊTEMENTS<br>STOFFGRUPPE<br>TAPICERÍAS |
|---|--|---|------|--|--|
|   |  |   |      |  | G  |
|   | <b>3D SOFT</b>   | <b>XB096</b>                                | 2,60 | 145  |  |
|   | <b>4D EXTRASOFT</b>  | <b>XB090</b>                                | 2,60 | 161  |  |
|   | Poggiatesta<br>Headrest<br>Appui-tête<br>Kopfstütze<br>Reposacabezas   | <b>XT002</b>                                | 0,80 | 132  |  |
|   | Poggiatesta regolabile<br>Adjustable headrest<br>Appui-tête réglable<br>Verstellbare Kopfstütze<br>Reposacabezas ajustable | <b>XT015</b>                                | 0,80 | 158  |  |
|   | Sedile Comfort<br>Comfort Seats<br>Assise Confort<br>Komfort Sitz<br>Asiento Confortable                                   | <b>XD018</b>                                | 0,60 | 25   |  |

# MOVING73Task

idea: *Pietro Lovato*



## 1. SCHIENALE:

Schienale regolabile in altezza (corsa 6cm). Con struttura portante in tubo tondo d'acciaio, Ø 16mm, schiumato a freddo in poliuretano espanso indeformabile, ignifugo secondo la norma UNI 9175, rivestito.

## 2. SEDILE:

Sedile con struttura portante in tubo tondo d'acciaio, Ø 16mm, schiumato a freddo in poliuretano espanso indeformabile, ignifugo secondo la norma UNI 9175, spessore 85mm, rivestito.

## 3. MECCANISMO:

- Mini-Synchro, comando elevazione a gas, regolazione tensione dello schienale, inclinazione 18° sch. Blocco e sblocco oscillazione schienale in 2 posizioni con antishock.
- Mini-Synchro, comando elevazione a gas, regolazione tensione dello schienale, inclinazione 18° sch. Inclinazione negativa del sedile 8°. Blocco e sblocco oscillazione schienale in 2 posizioni con antishock.

## 4. GAS:

Regolabile in altezza, rotazione, fin. nera.

## 5. BASE:

- 5 razze in poliamide con carica di fibra di vetro, Ø 680mm, finitura nera.
- 5 razze in alluminio, Ø 670mm, finitura lucida.

## 6. RUOTE:

Ruote Ø 50mm, autofrenanti o autofrenanti e gommate, finitura nera.

## 7. BRACCIOLI:

Con struttura portante in acciaio, schiumato a freddo in poliuretano espanso indeformabile, fissi o regolabili, rivestiti.

## 1. BACKREST:

Height adjustable backrest (6cm). Supporting structure made of round steel tube, Ø 16mm, polyurethan cold injected foam, non-deformable, fireproof according to the UNI 9175, upholstered.

## 2. SEAT:

Seat with supporting structure made of round steel tube, Ø 16mm, polyurethan cold injected foam, non-deformable, fireproof according to the UNI 9175, thickness 85mm, upholstered.

## 3. MECHANISM:

- Mini-Synchro, gas lift height adj., backrest tension adj., 18°grade backrest inclination with 2 locking position and antishock.
- Mini-Synchro, gas lift height adj., backrest tension adj., 18°grade backrest inclination with 2 locking position and antishock, 8° negative seat inclination.

## 4. GAS LIFT:

Height adjustable, swivel, black finish.

## 5. BASE:

- Fiberglass reinforced polyamide 5 spoke base, Ø 680mm, black finish.
- Polished aluminium 5 spoke base, Ø 670mm.

## 6. CASTORS:

Ø 50mm, self-braking castors or soft self-braking castors, black finish.

## 7. ARMREST:

Armrests with supporting structure made of steel, polyurethan cold injected foam, non-deformable, fixed or adjustable, upholstered.

## 1. DOSSIER:

Dossier réglable en hauteur (course 6 cm). Structure portante en tube en acier rond, Ø 16 mm, mousse en polyuréthane moulé à froids indéformable, non feu selon la norme UNI 9175, revêtu.

## 2. ASSISE:

Assise structure portante en tube en acier rond, Ø 16 mm, mousse en polyuréthane moulé à froids indéformable, non feu selon la norme UNI 9175, épaisseur 85 mm, revêtu.

## 3. MECANISME:

- Mini-Synchro, réglable en hauteur, réglage de tention du dossier, inclinaison 18. Blocage te déblocage du dossier en 2 positions avec système anti-choc.
- Mini-Synchro, réglable en hauteur, réglage de tention du dossier, inclinaison 18°. Inclinacion négative de l'assise 8°. Blocage te déblocage du dossier en 2 positions avec système anti-choc.

## 4. VERIN A GAZ:

Réglable en hauteur, pivotant, finition noir, tabouret.

## 5. PIÈTEMENT:

- Piètement 5 branches en polyamide renforcé en fibre de verre, Ø 680mm, finition noir.
- Piètement 5 branches en alu poli, Ø 670mm.

## 6. ROULETTES:

Roulettes Ø 50mm, autofreinantes ou autofreinantes gommées, finition noir.

## 7. ACCOUDOIR:

Accoudoirs avec structure portante en tube en acier, mousse en polyuréthane moulé à froids indéformable, fixes ou réglables, revêtus.

## 1. RÜCKENLEHNE:

Höhenverstellbare Rückenlehne (6 cm), Stahlrohrrahmen Ø 16mm, mit unverformbaren Polyurethan-Kaltschaum geschäumt und bezogen, feuerfest nach der norm Norm UNI 9175, tapizado.

## 2. SITZ:

Mit tragendem Stahlrohrrahmen Ø 16mm, mit unverformbaren Polyurethan-Kaltschaum geschäumt und bezogen, feuerfest nach der Norm UNI 9175, Dicke des Sitzkissen 85mm.

## 3. MECHANIK:

- Mini-Synchro, Gasliftsteuerung, Rückenlehne mit Spannungsregler, Rückenlehneigung 18° mit 2-stufige Arretierung.
- Mini-Synchro, Gasliftsteuerung, Rückenlehne mit Spannungsregler, Rückenlehneigung 18° mit 2-stufige Arretierung, Negative Sitzneigung 8°.

## 4. GASFEDER:

Sitzhöhenverstellung, drehbar, schwarz.

## 5. GESTELL:

- 5-Stern schwarzes glasfaserverstärktes Polyamid Fußkreuz, Ø 680mm.
- 5-Stern Alu poliertes Fußkreuz, Ø 670mm.

## 6. ROLLEN:

Gebremste schwarze Rollen Ø 50mm, für weiche oder harte Bodenbeläge.

## 7. ARMLEHNEN:

Feste oder verstellbare Armlehnen, aus tragende Stahlstruktur, mit Polyurethan-Kaltschaum geschäumt.

## 1. RESPALDO:

Respaldo ajustable en altura (6cm). Estructura de soporte en tubo de acero redondo, Ø 16mm, espuma de poliuretano inyectada a frío, indeformable, ignifugo según el estándar UNI 9175, tapizado.

## 2. ASIENTO:

Asiento con estructura de soporte en tubo de acero redondo, Ø 16mm, espuma de poliuretano inyectada a frío, indeformable, ignifugo según el estándar UNI 9175, espesor 85mm, tapizado.

## 3. MECANISMO:

- Mini-Synchro, control de elevación a gas, ajuste de tensión posterior, inclinación 18° respaldo. Bloqueo y desbloqueo de la oscilación del respaldo en 2 posiciones con antishock.
- Mini-Synchro, control de elevación a gas, ajuste de tensión posterior, inclinación 18° respaldo. Inclinación negativa asiento 8°. Bloqueo y desbloqueo de la oscilación del respaldo en 2 posiciones con antishock.

## 4. GAS:

Ajustable en altura, rotación, acabado negro.

## 5. BASE:

- Base 5 estrellas en poliamide con carga de fibra de vidrio, Ø 680mm, acabado negro.
- Base 5 estrellas en aluminio, Ø 670mm, acabado brillante.

## 6. RUEDAS:

Rueda de Ø 50mm, autofrenantes o autofrenantes y blandas, acabado negro.

## 7. BRAZOS:

Brazos con estructura de soporte en acero, espuma de poliuretano inyectada a frío, indeformable, fijos o ajustables, tapizados.



# MOVING73Task

IMBOTTITA, SCH. REG. IN ALTEZZA  
UPHOLSTERED, HEIGHT ADJ. BACKREST  
REMOURE, DOSSIER REGL. EN HATEUR  
GEPOLSTERT, HÖHENVERST. RÜCKENLEHNE  
TAPIZADA, RESPALDO REGLABLE

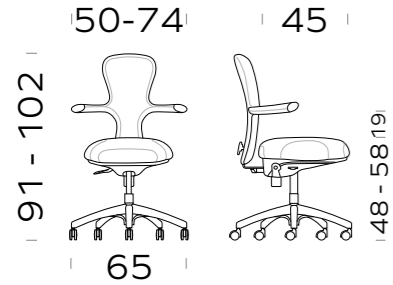

Mechanism: **MiniSynchro**

Blocco oscillante, Regolazione altezza/tensione  
(Un-)locking device, Height/tension adjustment  
Système de blocage-débloccage de l'oscillation, Réglage en hauteur/ d'intensité  
Blockierung der Rückenlehnen /Spannungsregler / Höhenverstellung  
Sistema de bloqueo-desbloqueo del respaldo, Ajuste de altura/tensión

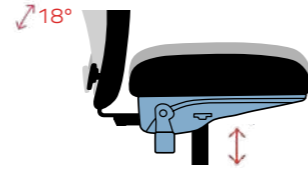

| BASE<br>BASE<br>PIETEMET<br>GESTELL<br>BASE   | RUOTA/PIEDINO<br>CASTOR/FEET<br>ROULETTES/PATINS<br>ROLLEN/GLEITER<br>RUEDAS/PIES  | STRUTTURA<br>STRUCTURE<br>STRUCTURE<br>STRUKTUR<br>ESTRUCTURA | BRACCIOLI<br>ARMRESTS<br>ACCOUDOIRS<br>ARMLEHNEN<br>BRAZOS          | CODICE<br>CODE<br>CODE<br>ARTIKEL<br>CÓDIGO | KG    | SCHIENALE<br>BACKREST<br>DOSSIER<br>RÜCKENLEHNE<br>RESPALDO | TESSUTI/FINITURE<br>UPHOLSTERIES/FINISHING<br>REVETEMENTS<br>STOFFGRUPPE<br>TAPICERIAS |     |
|---|--|---|---|---|-------|---|--|-----|
|   |  |   |   |   |       |   | E  | F   |
|   |  |   | fissi<br>fixed<br>fixes<br>feste<br>fijos                           | MO0012                                      | 14,40 | E   | 630  | 643 |
|   |  |   |   |   |       | F   |  | 670 |
| 5 razze poliammide nera<br>5-spoke black polyamide<br>5 branches polyamide noir<br>5-Stern schwarzes Polyamid Fußkreuz<br>estrella en poliamida negra | d.50mm autofrenanti gommata<br>soft self-braking d.50mm<br>d.50mm gommées autofreinante<br>weiche gebremste D.50 mm<br>ruedas goma diam.50 autofreno | RAL 9005  | regolabili<br>adjustable<br>réglables<br>verstellbare<br>ajustables | MO0008                                      | 16,10 | E   | 823  | 837 |
|   |  |   |   |   |       | F   |  | 864 |
|   |  | Polished  | fissi<br>fixed<br>fixes<br>feste<br>fijos                           | MO0010                                      | 14,20 | E   | 739  | 752 |
|   |  |   |   |   |       | F   |  | 779 |
| 5 razze in alluminio lucida<br>5-spoke polished aluminium<br>5 branches alu poli<br>5-Stern Alu poliertes Fußkreuz<br>estrella en aluminio pulido     | d.50mm autofrenanti gommata<br>soft self-braking d.50mm<br>d.50mm gommées autofreinante<br>weiche gebremste D.50 mm<br>ruedas goma diam.50 autofreno | Polished  | regolabili<br>adjustable<br>réglables<br>verstellbare<br>ajustables | MO0006                                      | 16,20 | E   | 932  | 946 |
|   |  |   |   |   |       | F   |  | 973 |

\* DISPONIBILE ANCHE IN  
ALSO AVAILABLE  
ÉGALEMENT DISPONIBLE EN  
ERHÄLTICH AUCH IN  
TAMBIÉN DISPONIBLE EN

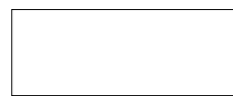

RAL 9016



RAL 6021



RAL 1012



RAL 7032



RAL 3012



RAL 7046

\* DISPONIBILE ANCHE CON  
ALSO AVAILABLE WITH  
ÉGALEMENT DISPONIBLE AVEC  
ERHÄLTICH AUCH MIT  
TAMBIÉN DISPONIBLE CON



d.50 mm autofrenanti  
self-braking d.50mm  
d.50mm autofreinante  
gebremste D.50mm  
diam.50 autofreno

**SAME PRICE**

# MOVING73Task

IMBOTTITA, SCH. REG. IN ALTEZZA  
UPHOLSTERED, HEIGHT ADJ. BACKREST  
REMOURE, DOSSIER REGL. EN HATEUR  
GEPOLSTERT, HÖHENVERST. RÜCKENLEHNE  
TAPIZADA, RESPALDO REGLABLE

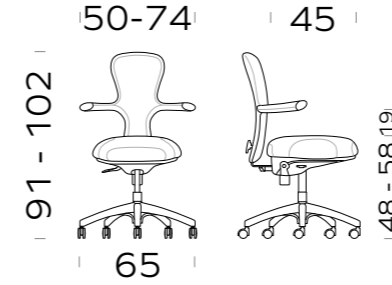

Mechanism: **MiniSynchro Neg**

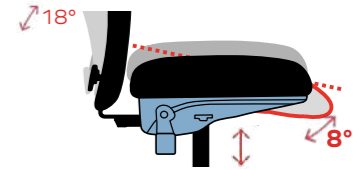

| BASE<br>BASE<br>PIETEMET<br>GESTELL<br>BASE   | RUOTA/PIEDINO<br>CASTOR/FEET<br>ROULETTES/PATINS<br>ROLLEN/GLEITER<br>RUEDAS/PIES  | STRUTTURA<br>STRUCTURE<br>STRUCTURE<br>STRUKTUR<br>ESTRUCTURA | BRACCIOLI<br>ARMRESTS<br>ACCOUDOIRS<br>ARMLEHNEN<br>BRAZOS          | CODICE<br>CODE<br>CODE<br>ARTIKEL<br>CÓDIGO | KG    | SCHIENALE<br>BACKREST<br>DOSSIER<br>RÜCKENLEHNE<br>RESPALDO | TESSUTI/FINITURE<br>UPHOLSTERIES/FINISHING<br>REVETEMENTS<br>STOFFGRUPPE<br>TAPICERIAS |      |
|---|--|---|---|---|-------|---|--|------|
|   |  |   |   |   |       |   | E  | F    |
|   |  |   | fissi<br>fixed<br>fixes<br>feste<br>fijos                           | MO0020                                      | 16,40 | E   | 722  | 736  |
|   |  |   |   |   |       | F   |  | 763  |
| 5 razze poliammide nera<br>5-spoke black polyamide<br>5 branches polyamide noir<br>5-Stern schwarzes Polyamid Fußkreuz<br>estrella en poliamida negra | d.50mm autofrenanti gommata<br>soft self-braking d.50mm<br>d.50mm gommées autofreinante<br>weiche gebremste D.50 mm<br>ruedas goma diam.50 autofreno | RAL 9005  | regolabili<br>adjustable<br>réglables<br>verstellbare<br>ajustables | MO0016                                      | 18,10 | E   | 916  | 930  |
|   |  |   |   |   |       | F   |  | 957  |
|   |  | Polished  | fissi<br>fixed<br>fixes<br>feste<br>fijos                           | MO0018                                      | 16,40 | E   | 831  | 845  |
|   |  |   |   |   |       | F   |  | 872  |
| 5 razze in alluminio lucida<br>5-spoke polished aluminium<br>5 branches alu poli<br>5-Stern Alu poliertes Fußkreuz<br>estrella en aluminio pulido     | d.50mm autofrenanti gommata<br>soft self-braking d.50mm<br>d.50mm gommées autofreinante<br>weiche gebremste D.50 mm<br>ruedas goma diam.50 autofreno | Polished  | regolabili<br>adjustable<br>réglables<br>verstellbare<br>ajustables | MO0014                                      | 18,10 | E   | 1025   | 1038 |
|   |  |   |   |   |       | F   |  | 1066 |

\* DISPONIBILE ANCHE IN  
ALSO AVAILABLE  
ÉGALEMENT DISPONIBLE EN  
ERHÄLTICH AUCH IN  
TAMBIÉN DISPONIBLE EN

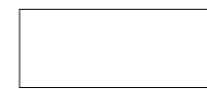

RAL 9016



RAL 3012



RAL 7032



RAL 1012



RAL 6021



RAL 7046

| OPZIONE<br>OPTIONALS<br>OPTIONEN<br>OPCIONES | VARIANTE<br>VARIANT<br>VARIANTE<br>VARIANTE   | CODICE<br>CODE<br>CODE<br>ARTIKEL<br>CÓDIGO | KG   | PREZZO<br>PRICE<br>PREIS<br>PRECIO |
|--|---|---|------|------------------------------------|
|  | per base alluminio<br>for polished alu base<br>pour piétement alu poli<br>zu Alu-Fußkreuz<br>por base aluminio      | XP006                                       | 1,10 | 68                                 |
|  | per base poliammide<br>for polyamide base<br>pour piétement polyamide<br>zu Polyamid Fußkreuz<br>por base poliamide | XP005                                       | 1,10 | 49                                 |

\* DISPONIBILE ANCHE CON  
ALSO AVAILABLE WITH  
ÉGALEMENT DISPONIBLE AVEC  
ERHÄLTICH AUCH MIT  
TAMBIÉN DISPONIBLE CON



d.50 mm autofrenanti  
self-braking d.50mm  
d.50mm autofreinante  
gebremste D.50mm  
diam.50 autofreno

**SAME PRICE**

# MOVING73 Task Stool

idea: *Pietro Lovato*



## 1. SCHIENALE:

Schienale regolabile in altezza (corsa 6cm). Con struttura portante in tubo tondo d'acciaio, Ø 16mm, schiumato a freddo in poliuretano espanso indeformabile, ignifugo secondo la norma UNI 9175, rivestito.

## 2. SEDILE:

Sedile con struttura portante in tubo tondo d'acciaio, Ø 16mm, schiumato a freddo in poliuretano espanso indeformabile, ignifugo secondo la norma UNI 9175, spessore 85mm, rivestito.

## 3. MECCANISMO:

Mini-Synchro, comando elevazione a gas, regolazione tensione dello schienale, inclinazione 18° sch. Inclinazione negativa del sedile 8°. Blocco e sblocco oscillazione schienale in 2 posizioni con antishock.

## 4. GAS:

Regolabile in altezza, rotazione, fin. nera.

## 5. BASE:

- 5 razze in poliamide con carica di fibra di vetro, Ø 680mm, finitura nera.
- 5 razze in alluminio, Ø 670mm, finitura lucida.

Poggiapiedi a pentagono verniciato nero.

## 6. RUOTE:

Ruote Ø 50mm, autobloccanti gommate, finitura nera.

## 7. BRACCIOLI:

Con struttura portante in acciaio, schiumato a freddo in poliuretano espanso indeformabile, fissi o regolabili, rivestiti.

## 1. BACKREST:

Height adjustable backrest (6cm). Supporting structure made of round steel tube, Ø 16mm, polyurethan cold injected foam, non-deformable, fireproof according to the UNI 9175, upholstered.

## 2. SEAT:

Seat with supporting structure made of round steel tube, Ø 16mm, polyurethan cold injected foam, non-deformable, fireproof according to the UNI 9175, thickness 85mm, upholstered.

## 3. MECHANISM:

Mini-Synchro, gas lift height adj., backrest tension adj., 18° grade backrest inclination with 2 locking position and antishock, 8° negative seat inclination.

## 4. GAS LIFT:

Height adjustable, swivel, black finish.

## 5. BASE:

- Fiberglass reinforced polyamide 5 spoke base, Ø 680mm, black finish.
- Polished aluminium 5 spoke base, Ø 670mm.

Black painted pentagon footrest.

## 6. CASTORS:

Ø 50mm, soft self-locking castors, black finish.

## 7. ARMREST:

Armrests with supporting structure made of steel, polyurethan cold injected foam, non-deformable, fixed or adjustable, upholstered.

## 1. DOSSIER:

Dossier réglable en hauteur (course 6 cm). Structure portante en tube en acier rond, Ø 16 mm, mousse en polyuréthane moulé à froids indéformable, non feu selon la norme UNI 9175, revêtu.

## 2. ASSISE:

Assise structure portante en tube en acier rond, Ø 16 mm, mousse en polyuréthane moulé à froids indéformable, non feu selon la norme UNI 9175, épaisseur 85 mm, revêtu.

## 3. MECANISME:

Mini-Synchro, réglable en hauteur, réglage de tension du dossier, inclinaison 18°. Inclinaison négative de l'assise 8°. Blocage et déblocage du dossier en 2 positions avec système anti-choc.

## 4. VERIN A GAZ:

Réglable en hauteur, pivotant, finition noir, tabouret.

## 5. PIÈTEMENT:

- Piètement 5 branches en polyamide renforcé en fibre de verre, Ø 680mm, finition noir.
- Piètement 5 branches en alu poli, Ø 670mm.

Appui-pieds en forme de pentagone, verni noir.

## 6. ROULETTES:

Roulettes Ø 50mm, autobloquantes gommées, finition noir.

## 7. ACCOUDOIR:

Accoudoirs avec structure portante en tube en acier, mousse en polyuréthane moulé à froids indéformable, fixes ou réglables, revêtus.

## 1. RÜCKENLEHNE:

Höhenverstellbare Rückenlehne (6 cm), Stahlrohrrahmen Ø 16mm, mit unverformbaren Polyurethan-Kaltschaum geschäumt und bezogen, feuerfest nach der norm Norm UNI 9175.

## 2. SITZ:

Mit tragendem Stahlrohrrahmen Ø 16mm, mit unverformbaren Polyurethan-Kaltschaum geschäumt und bezogen, feuerfest nach der Norm UNI 9175. Dicke des Sitzkissen 85mm.

## 3. MECHANIK:

Mini-Synchro, Gasliftsteuerung, Rückenlehne mit Spannungsregler, Rückenlehneigung 18° mit 2-stufige Arretierung. Negative Sitzneigung 8°.

## 4. GASFEDER:

Sitzhöhenverstellung, drehbar, schwarz.

## 5. GESTELL:

- 5-Stern schwarzes glasfaserverstärktes Polyamid Fußkreuz, Ø 680mm.
- 5-Stern Alu poliertes Fußkreuz, Ø 670mm.

Pentagon Fußstütze, schwarz lackiert oder verchromt.

## 6. ROLLEN:

Weiche Stoppollen, Ø 50mm, schwarz.

## 7. ARMLEHNEN:

Feste oder verstellbare Armlehnen, aus tragende Stahlstruktur, mit Polyurethan-Kaltschaum geschäumt.

## 1. RESPALDO:

Respaldo ajustable en altura (6cm). Estructura de soporte en tubo de acero redondo, Ø 16mm, espuma de poliuretano inyectada a frío, indeformable, ignifugo según el estándar UNI 9175, tapizado.

## 2. ASIENTO:

Asiento con estructura de soporte en tubo de acero redondo, Ø 16mm, espuma de poliuretano inyectada a frío, indeformable, ignifugo según el estándar UNI 9175, espesor 85mm, tapizado.

## 3. MECANISMO:

Mini-Synchro, control de elevación a gas, ajuste de tensión posterior, inclinación 18° respaldo. Inclinación negativa asiento 8°. Bloqueo y desbloqueo de la oscilación del respaldo en 2 posiciones con antishock.

## 4. GAS:

Ajustable en altura, rotación, acabado negro.

## 5. BASE:

- Base 5 estrellas en poliamide con carga de fibra de vidrio, Ø 680mm, acabado negro.
- Base 5 estrellas en aluminio, Ø 670mm, acabado brillante.

Reposapiés pentagonal pintado negro.

## 6. RUEDAS:

Rueda de Ø 50mm, autobloqueantes blandas, acabado negro.

## 7. BRAZOS:

Brazos con estructura de soporte en acero, espuma de poliuretano inyectada a frío, indeformable, fijos o ajustables, tapizados.



# MOVING73Task Stool



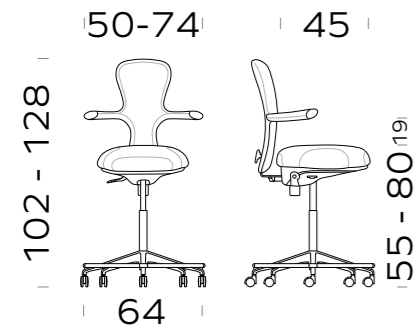

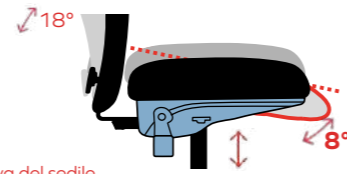

IMBOTTITA, SCH. REG. IN ALTEZZA  
UPHOLSTERED, HEIGHT ADJ. BACKREST  
REMBOURRE, DOSSIER REGL. EN HATEUR  
GEPOLSTERT, HÖHENVERST. RÜCKENLEHNE  
TAPIZADA, RESPALDO REGLABLE



Mechanism: **MiniSynchro Neg**  
Neg↓

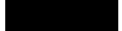

Blocco oscillante, Regolazione altezza/tensione, Inclinazione negativa del sedile  
(Un-)locking device, Height/tension adjustment, Adjustment of seat negative inclination  
Système de blocage-déblocage de l'oscillation, Réglage en hauteur/ d'intensité, Inclinaison négative de l'assise  
Blockierung der Rückenlehnen /Spannungsregler / Höhenverstellung, Sitzneigungsverstellung  
Sistema de bloqueo-desbloqueo del respaldo, Ajuste de altura/tensión, Inclinación negativa asiento

| BASE<br>BASE<br>PIETEMENT<br>GESTELL<br>BASE  | RUOTA/PIEDINO<br>CASTOR/FEET<br>ROULETTES/PATINS<br>ROLLEN/GLEITER<br>RUEDAS/PIES  | STRUTTURA<br>STRUCTURE<br>STRUCTURE<br>STRUKTUR<br>ESTRUCTURA                                       | BRACCIOLI<br>ARMRESTS<br>ACCOUDOIRS<br>ARMLEHNEN<br>BRAZOS          | CODICE<br>CODE<br>ARTIKEL<br>CÓDIGO | KG    | SCHIENALE<br>BACKREST<br>DOSSIER<br>RÜCKENLEHNE<br>RESPALDO | TESSUTI/FINITURE<br>UPHOLSTERIES/FINISHING<br>REVETEMENTS<br>STOFFGRUPPE<br>TAPICERIAS |
|---|--|---|---|-------------------------------------|-------|---|--|
|  <p>5 razze poliammide nera<br/>5-spoke black polyamide<br/>5 branches polyamide noir<br/>5-Stern schwarzes Polyamid Fußkreuz<br/>estrella en polyamida negra</p> |  <p>d.50mm autobloccanti gommata<br/>soft self-locking d.50mm<br/>d.50mm autobloquantes gommées<br/>weiche Stoprollen D.50mm<br/>diam.50 autobloquantes blandas</p>   |  <p>RAL 9005</p>   | fissi<br>fixed<br>fixes<br>feste<br>fijos                           | M00004                              | 18,20 | E   | 826  |
|   |  |   | regolabili<br>adjustable<br>réglables<br>verstellbare<br>ajustables | M00002                              | 19,90 | E   | 1020   |
|  <p>5 razze in alluminio lucida<br/>5-spoke polished aluminium<br/>5 branches alu poli<br/>5-Stern Alu poliertes Fußkreuz<br/>estrella en aluminio pulido</p>   |  <p>d.50mm autobloccanti gommata<br/>soft self-locking d.50mm<br/>d.50mm autobloquantes gommées<br/>weiche Stoprollen D.50mm<br/>diam.50 autobloquantes blandas</p> |  <p>Polished</p> | fissi<br>fixed<br>fixes<br>feste<br>fijos                           | M00003                              | 18,20 | E   | 934  |
|   |  |   | regolabili<br>adjustable<br>réglables<br>verstellbare<br>ajustables | M00001                              | 19,80 | E   | 1128   |
|   |  |   |   |                                     |       | F   | 1156   |

\* DISPONIBILE ANCHE IN  
ALSO AVAILABLE  
ÉGALEMENT DISPONIBLE EN  
ERHÄLTlich AUCh IN  
TAMBIÉN DISPONIBLE EN



RAL 9016



RAL 1012



RAL 3012



RAL 6021





RAL 7032



RAL 7046

# MOVING73Task Stool

## OPTIONALS

| OPZIONE<br>OPTIONALS<br>OPTIONS<br>OPCIONES   | VARIANTE<br>VARIANT<br>VARIANTE<br>VARIANTE   | CODICE<br>CODE<br>ARTIKEL<br>CÓDIGO | KG   | PREZZO<br>PRICE<br>PRIX<br>PREIS<br>PRECIO |
|---|---|-------------------------------------|------|--|
|  |  <p>per base alluminio<br/>for polished alu base<br/>pour piètement alu poli<br/>zu Alu-Fußkreuz<br/>por base aluminio</p> | XP003                               | 1,10 | 19   |

# ECOCHAIR

idea: *Pietro Lovato*



## 1. SCHIENALE:

Schienale in poliamide con carica di fibra di vetro, finitura nera o bianca, rivestito in rete, supporto lombare regolabile e imbottito

## 2. SEDILE:

Sedile in polipropilene imbottito con spugna schiumata a freddo rivestito

## 3. MECCANISMO:

• SynchroPlus+, comando elevazione a gas, regolazione tensione schienale, inclinazione 20°sch. 8°sed. in 5 posizioni con antishock, traslazione sed. 6cm in 5 posizioni

## 4. GAS:

• Regolabile in altezza, rotazione, finitura cromata  
• Regolabile in altezza, rotazione, finitura nera  
• Regolabile in altezza, rotazione, finitura cromata, sgabello

## 5. BASE:

• Base 5 razze in poliamide con carica di fibra di vetro, Ø 700mm, finitura nero  
• Base 5 razze in alluminio, Ø 700mm, finitura lucida  
• Base 5 razze in poliamide con carica di fibra di vetro, Ø 680mm, finitura nero

## 6. RUOTE/PIEDINI:

• Ruote Ø 50mm, autofrenanti o autofrenanti e gommate, finitura nera  
• Piedini in polimero termoplastico, h. 68mm, finitura cromata (15µm)  
• Piedini in poliamide, h. 61mm, finitura nera

## 7. BRACCIOILI:

• Bracciolo regolabile in altezza in tubo ellittico d'acciaio, 40x20mm, finitura cromata (15µm) verniciata a polveri, con top in poliamide, finitura nera (tavoletta in polipropilene)  
• Bracciolo regolabile in tubo ellittico d'acciaio, 40x20mm, finitura cromata (15µm) o verniciata a polveri, con top in poliamide, finitura nera, o top in poliuretano morbido  
• Bracciolo regolabile in 3D in tubo ovale d'acciaio, 45x25mm, finitura cromata, con top in poliuretano morbido  
• Bracciolo regolabile 4D con top morbido in poliuretano, regolazione 360° silenziosa  
• Bracciolo fisso in piatto d'acciaio, 30x5mm, finitura cromata (15µm) rivestito  
• Bracciolo fisso in tubo tondo d'acciaio, Ø 16mm, finitura cromata (15µm) o verniciata a polveri, con top in poliamide, finitura nera  
• Braccioli fissi poliamide

## 1. BACKREST:

Fiberglass reinforced polyamide backrest, black or white finish, upholstered in mesh, adjustable and padded lumbar support

## 2. SEAT:

Polypropylene seat, cold injected foam padded, upholstery

## 3. MECHANISM:

• SynchroPlus+, gas lift height adj. Backrest tension adj. backrest inclination 20° in 5 locking position with antishock, seat inclination 8°. Sliding seat device 6cm in 5 positions

## 4. GAS LIFT:

• Réglable en hauteur, swivel, chromed finish  
• Réglable en hauteur, swivel, Black finish  
• Stool version height adjustable, swivel, chromed finish

## 5. BASE:

• Fiberglass reinforced polyamide 5 spoke base, Ø 700 mm, black finish  
• Polished aluminium 5 spoke base, Ø 700 mm  
• Fiberglass reinforced polyamide 5 spoke base, Ø 680 mm, black finish

## 6. CASTORS/FEET:

• Ø 50 mm self-braking castors, or soft self-bracking, Black finish  
• h.68mm Thermoplastic polymer gliders chromed finish (15µm)  
• h.61 mm polyamide glides, black finish

## 7. ARMREST:

• Height adj. Armrest, Ellipt Steel tube 40x20mm, chromed finish (15µm) or powder coated, polyamide pad, black finish (writing tablet in polypropylene)  
• Height adj. Armrest, Ellipt. Steel tube 40x20mm, chromed finish (15µm) or powder coated, polyamide pad, black finish or soft polyurethane pad.  
• 3D adj. armrest, in oval steel tube 45x25mm, chromed finish, soft polyurethane pad  
• 4D Armrest, soft polyurethane pad, soundless adjustment 360°  
• Steel plate fixed armrest, 30x5mm, chromed finish (15µm), upholstered  
• Fixed armrest, round steel tube, Ø 16mm, chromed finish (15µm), or powder coated, polyamide top pad, black finish  
• Fixed polyamide armrests

## 1. DOSSIER:

Dossier en polyamide renforcé en fibre de verre, finition noir ou blanc, revetu en résille, avec soutien lombaire réglable et rembourré

## 2. ASSISE:

Assise en polypropylène rembourrée de mousse moulée à froids, tapissée

## 3. MECANISME:

• SynchroPlus+, réglage en hauteur, réglage de tension, inclinaison dossier 20°et assise 8°, en 5 positions avec système anti-choc, profondeur d'assise 6 cm en 5 positions

## 4. VERIN A GAZ:

• Réglable en hauteur, pivotant, finition chromé  
• Réglable en hauteur, pivotant, finition noir  
• Réglable en hauteur, pivotant, finition chromé, tabouret

## 5. PIETEMENT:

• Piètement 5 branches en polyamide renforcé en fibre de verre, Ø 700mm, finition noir  
• Piètement 5 branches alu poli, Ø 700mm  
• Piètement 5 branches en polyamide renforcé en fibre de verre, Ø 680mm, finition noir

## 6. ROULETTES/PATINS:

• Roulettes Ø 50mm, autofrenantes ou autofrenantes et gommées, finition noir  
• Patins en polymère thermoplastique, h.68mm, finition chromée (15µm)  
• Patins en polyamide, h.61mm, finition noir

## 7. ACCOUDOIR:

• Accoudoir réglable en hauteur en tube d'acier elliptique, 40x20mm, finition chromé (15µm) ou verni époxy, manchette en polyamide, finition noir  
• Accoudoir réglable en tube d'acier elliptique, 40x20mm, finition chromé (15µm) ou verni époxy, manchette en polyamide, finition noir ou en polyuréthane souple  
• Accoudoir réglable en 3D en tube ovale d'acier, 45x25mm, finition chromé, manchette en polyuréthane souple  
• Accoudoir 4D manchette en polyuréthane souple, pivotant 360°, réglage silencieux  
• Accoudoir fixe plat en acier, 30x5mm, finition chromé (15µm) tapissé  
• Accoudoir fixe en tube rond d'acier, Ø 16mm, finition chromé (15µm) ou verni époxy, manchette en polyamide, finition noir  
• Accoudoirs fixes polyamide

## 1. RÜCKENLEHNE:

Rückenlehne aus glasfaserverstärkten Polyamid, schwarz oder weiß, Netzbezug mit integrierte verstellbare gepolsterte Polyamid Lumbalstütze

## 2. SITZ:

Polypropylen Sitz, ausgepolstert mit Kaltgeschäumten Polyurethan, mit Bezug

## 3. MECHANIK:

• SynchroPlus+, Gaslift Höhenverstellung, Rückenlehne mit Spannungsregler, 20°Rückenlehneigung, 8°Sitzneigung, 5-stufige Einstellung mit Antishock, 6 cm Sitztiefenverstellung mit 5 Positionen

## 4. GASFEDER:

• Sitzhöhenverstellung, drehbar, verchromt  
• Sitzhöhenverstellung, drehbar, schwarz  
• Hocker Sitzhöhenverstellung, drehbar, verchromt

## 5. GESTELL:

• 5-sterne glasfaserverstärktpolyamid Fußkreuz, Ø 700 mm, schwarz  
• 5-Stern Alu poliertes Fußkreuz, Ø 700 mm  
• 5-Stern schwarzes glasfaserverstärktes Polyamid Fußkreuz, Ø 680 mm

## 6. ROLLEN/GLEITER:

• Ø 50 mm gebremste, oder weiche gebremste Rollen, schwarz  
• Thermoplastische Polymergleiter, H.68 mm, verchromt (15µm)  
• Polyamidgleiter, H.61 mm, schwarz

## 7. ARMLEHNEN:

• Höhenverstellbare Armlehne aus Ellipt. Stahlrohr, 40x20 mm, verchromt (15µm) oder pulverbeschichtet, schwarze Polyamid Armauflage (Ablageplatte aus Polypropylen)  
• Verstellbare Armlehne aus Ellipt. Stahlrohr, 40x20mm, verchromt (15µm) oder pulverbeschichtet, schwarze Polyamid Armauflage oder weichen Polyurethan  
• 3D verstellbare Armlehne aus Ellipt. Stahlrohr, 45x25mm, verchromt (15µm) schwarze Polyamid weiche Armauflage  
• 4D Armlehne schwarz, PU Armauflage, verschiebbar, geräuschlos 360° drehbar  
• Feste Armlehne aus Flachstahl 30x5 mm, verchromt (15µm) Gepolstert  
• Feste Armlehne aus Stahlrohr, Ø 16 mm, verchromt (15µm) oder pulverbeschichtet, schwarze Polyamid Armauflage  
• Ringarmlehnen aus Polyamid

## 1. RESPALDO:

Respaldo de poliamida con carga de fibra de vidrio, acabado negro o blanco, malla, soporte lumbar ajustable y acolchado

## 2. ASIENTO:

Asiento de polipropileno acolchado con espuma de espuma fría, tapizado

## 3. MECANISMO:

• SynchroPlus+, control de elevación de gas, ajuste de tensión posterior, inclinación respaldo 20° . 8° asiento En 5 posiciones con antishock, desplazamiento asiento 6cm en 5 posiciones.

## 4. GAS:

• Ajustable en altura, rotación, acabado cromado.  
• Ajustable en altura, rotación, acabado negro.  
• Altura regulable, rotación, acabado cromado, taburete

## 5. BASE:

• Base de 5 estrellas en poliamida con carga de fibra de vidrio, Ø 700 mm, acabado negro  
• Base de 5 estrellas en aluminio, Ø 700mm, acabado brillante.  
• Base de 5 radios en poliamida con carga de fibra de vidrio, Ø 680 mm, acabado negro

## 6. RUEDAS:

• Ruedas de Ø 50 mm, autofrenado o autofrenado y blandas, acabado negro  
• Pies en polímero termoplástico, h. 68 mm, acabado cromado (15µm) o negro  
• Pies en poliamida, h. 61mm, acabado negro

## 7. BRAZOS:

• Brazos ajustables en poliamida, acabado negro, con top de poliamida, acabado negro o top de poliuretano suave  
• Brazos ajustables en tubo de acero elíptico, 40x20 mm, acabado en cromo (15µm) o con recubrimiento en polvo, con top de poliamida, acabado en negro  
• Brazos 3D ajustables en tubo de acero ovalado, 45x25 mm, acabado cromado, con top de poliuretano suave  
• Brazos 4D, almohadilla en poliuretano suave, ajuste 360° sin sonido  
• Brazos fijo en tubo de acero 30x50mm, acabado cromado, tapizado  
• Brazos ajustables en tubo de acero elíptico, 40x20 mm, acabado en cromo (15µm) o con recubrimiento en polvo, con top de poliamida, acabado en negro  
• Brazos fijo en poliamida



ID 1111209681

# ECOCHAIR

SCHIENALE MEDIO IN RETE, SUPPORTO LOMBARE REGOLABILE, SEDILE IMBOTTITO  
 MESH MEDIUM BACKREST, ADJUSTABLE LUMBAR SUPPORT, UPHOLSTERED SEAT  
 DOSSIER MOYEN EN RÉVILLE, SOUTIEN LOMBAIRE RÉGLABLE, ASSISE REMBOURRÉ  
 NETZ MITTLERE RÜCKENLEHNE, VERSTELLBARE LUMBALSTÜTZE, GEPOLSTERT SITZ  
 MEDIO RESPALDO EN MALLA, SUPORTE LUMBAR REGLABLE, ASIENTO TAPIZADO

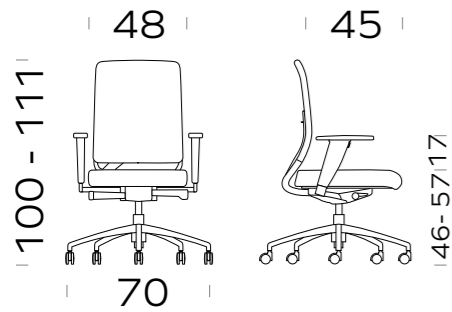

Mechanism: **SynchroPlus**  
 TECH INSIDE. SIMPLE OUTSIDE  
 Slide

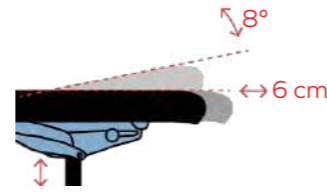

Blocco oscillante, Regolazione altezza/tensione, Regolazione in profondità del sedile  
 (Un-)locking device, Height/tension adjustment, Depth adjustment of the seat  
 Système de blocage-débloqué de l'oscillation, Réglage en hauteur/ d'intensité, Réglage en profondeur de l'assise  
 Blockierung der Rückenlehne /Spannungsregler / Höhenverstellung, Sitztiefeverstellung  
 Sistema de bloqueo-desbloqueo del respaldo, Ajuste de altura/tensión, Ajuste de profundidad del asiento

| BASE<br>BASE<br>PIETEMENT<br>GESTELL<br>BASE  | RUOTA/PIEDINO<br>CASTOR/FEET<br>ROULETTES/PATINS<br>ROLLEN/GLEITER<br>RUEDAS/PIES   | STRUTTURA<br>STRUCTURE<br>STRUCTURE<br>STRUKTUR<br>ESTRUCTURA | RETE<br>MESH<br>MAILLE<br>NETZ<br>MALLA | CODICE<br>CODE<br>CODE<br>ARTIKEL<br>CÓDIGO | KG    | TESSUTI/FINITURE<br>UPHOLSTERIES/FINISHING<br>REVETEMENTS<br>STOFFGRUPPE<br>TAPICERIAS |     |     |     |
|---|---|---|---|---|-------|--|-----|-----|-----|
|   |   |   |   |   |       | D  | E   | F   | G   |
|   |   |   | M-N                                     | EC0035                                      | 10,50 | 435  | 440 | 446 | 481 |
| 5 razze poliammide<br>5-spoke polyamide<br>5 branches polyamide<br>5 - Stern Polyamid Fußkreuz<br>estrella en poliamida                             | d.50mm autofrenanti gommate<br>soft self-braking d.50mm<br>d.50 mm gommées autofreinante<br>weiche gebremste D.50 mm<br>ruedas goma diam.50 autofreno | *   |   |   |       |  |     |     |     |
|   |   |   | M-N                                     | EC0056                                      | 10,70 | 440  | 447 | 451 | 489 |
| 5 razze design poliammide<br>5-spoke polyamide design<br>5 branches polyamide<br>5 - Stern Polyamid Design Fußkreuz<br>design estrella en poliamida | d.50mm autofrenanti gommate<br>soft self-braking d.50mm<br>d.50 mm gommées autofreinante<br>weiche gebremste D.50 mm<br>ruedas goma diam.50 autofreno | *   |   |   |       |  |     |     |     |
|   |   |   | M-N                                     | EC0080                                      | 11,20 | 496  | 502 | 506 | 545 |
| 5 razze in alluminio<br>5-spoke aluminium<br>5 branches alu<br>5-Stern Alu Fußkreuz<br>estrella en aluminio   | d.50mm autofrenanti gommate<br>soft self-braking d.50mm<br>d.50 mm gommées autofreinante<br>weiche gebremste D.50 mm<br>ruedas goma diam.50 autofreno |   | M-N                                     | EC0077                                      | 11,20 | 496  | 502 | 506 | 545 |
|   |   | *   |   |   |       |  |     |     |     |

\* DISPONIBILE ANCHE IN  
 ALSO AVAILABLE  
 ÉGALEMENT DISPONIBLE EN  
 ERHÄLTlich AUCH IN  
 TAMBIÉN DISPONIBLE EN

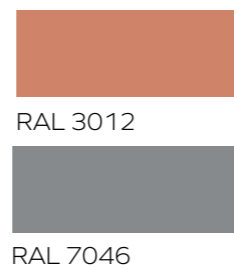
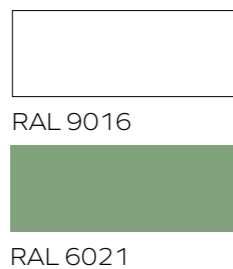

\* DISPONIBILE ANCHE CON  
 ALSO AVAILABLE WITH  
 ÉGALEMENT DISPONIBLE AVEC  
 ERHÄLTlich AUCH MIT  
 TAMBIÉN DISPONIBLE CON

d.50 mm autofrenanti  
 self-braking d.50mm  
 d.50mm autofreinante  
 gebremste D.50mm  
 diam.50 autofreno

**SAME PRICE**

# ECOCHAIR

## OPTIONALS

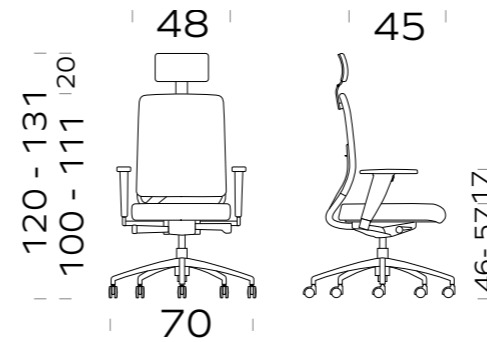

| OPZIONE<br>OPTIONALS<br>OPTIONS<br>OPCIONES | VARIANTE<br>VARIANT<br>VARIANTE<br>VARIANTE | CODICE<br>CODE<br>CODE<br>ARTIKEL<br>CÓDIGO | KG   | PREZZO<br>PRICE<br>PRIX<br>PREIS<br>PRECIO | TESSUTI/FINITURE<br>UPHOLSTERIES/<br>FINISHING<br>REVETEMENTS<br>STOFFGRUPPE<br>TAPICERIAS |   |   |   | OPZIONE<br>OPTIONALS<br>OPTIONS<br>OPCIONES | VARIANTE<br>VARIANT<br>VARIANTE<br>VARIANTE   | CODICE<br>CODE<br>CODE<br>ARTIKEL<br>CÓDIGO | KG   | PREZZO<br>PRICE<br>PRIX<br>PREIS<br>PRECIO | TESSUTI/FINITURE<br>UPHOLSTERIES/<br>FINISHING<br>REVETEMENTS<br>STOFFGRUPPE<br>TAPICERIAS |    |    |    |
|---|---|---|------|--|--|---|---|---|---|---|---|------|--|--|----|----|----|
|   |   |   |      |  | D  | E | F | G |   |   |   |      |  | D  | E  | F  | G  |
|   | 2D  | XB091                                       | 2,50 | 81   |  |   |   |   |   | 4D EXTRASOFT  | XB089                                       | 2,60 | 102  |  |    |    |    |
|   | 2D SOFT                                     | XB094                                       | 2,60 | 113  |  |   |   |   |   | 4D EXTRASOFT  | XB090                                       | 2,60 | 161  |  |    |    |    |
|   | 2D  | XB020                                       | 1,30 | 39   |  |   |   |   |   | Sedile Comfort<br>Comfort Seats<br>Assise Confort<br>Komfort Sitz<br>Asiento Confortable  | XD018                                       | 0,60 | 25   |  |    |    |    |
|   | 2D SOFT                                     | XB022                                       | 1,60 | 61   |  |   |   |   |   | Molle sedile<br>Seat springs<br>Resorts assise<br>Sitz Federkern<br>Resortes asientos   | XD001                                       | 0,80 | 37   |  |    |    |    |
|   | 3D  | XB021                                       | 1,30 | 71   |  |   |   |   |   | SEAT WITH<br>NEGATIVE<br>INCLINATION  | XM007                                       | 1,30 | 35   |  |    |    |    |
|   | 3D SOFT                                     | XB023                                       | 1,60 | 92   |  |   |   |   |   | Copri sedile removibile<br>Removable seat cover<br>Housse assise, amovible<br>Sitzbezug, abnehmbar<br>Funda para asiento<br>retirable | FOD180                                      |      |  | 36   | 40 | 48 |    |
|   | 3D  | XB092                                       | 2,50 | 107  |  |   |   |   |   | Poggiatesta regolabile<br>Adjustable headrest<br>Appui-tête réglable<br>Verstellbare Kopfstütze<br>Reposacabezas<br>ajustable         | XT007                                       | 0,80 |  | 92   | 92 | 94 | 96 |
|   | 3D SOFT                                     | XB087                                       | 2,50 | 145  |  |   |   |   |   | Poggiapiedi<br>Footrest<br>Appui-pieds<br>Fußstütze<br>Reposapiés   | ONLY<br>FOR<br>XP005<br>EC0035              | 1,10 | 49   |  |    |    |    |

\* DISPONIBILE ANCHE IN  
 ALSO AVAILABLE  
 ÉGALEMENT DISPONIBLE EN  
 ERHÄLTlich AUCH IN  
 TAMBIÉN DISPONIBLE EN

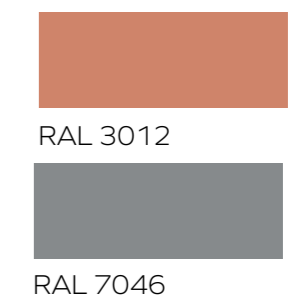
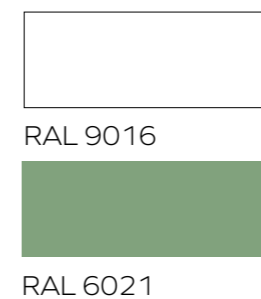

# ECOCHAIR Visitor

idea: *Pietro Lovato*

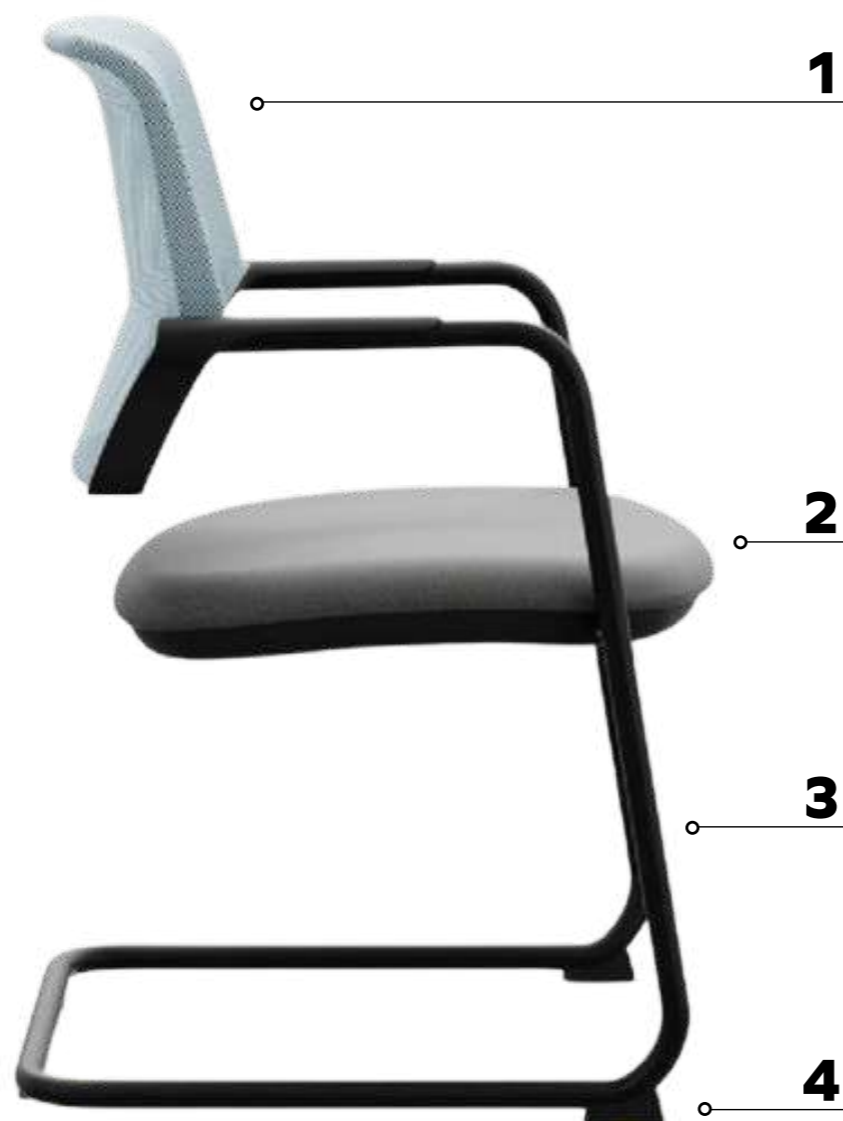

## TECHNICAL INFORMATION

### 1. SCHIENALE:

Schienale in poliamide con carica di fibra di vetro, finitura nera, o schienale in tubo d'acciaio integrato alla base, rivestito in rete

### 2. SEDILE:

- Sedile in multistrato di legno con spugna, rivestito
- Sedile in polipropilene imbottito con spugna, rivestito

### 3. BASE:

- Base a slitta in tubo d'acciaio Ø 25mm, finitura cromata (15µm) o verniciata a polveri
- Base 4 gambe in tubo d'acciaio Ø 22mm, finitura cromata (15µm) o verniciata a polveri

### 4. RUOTE/PIEDINI:

- Ruote Ø 50mm, autofrenanti o autofrenanti e gommate, finitura nera
- Tappi antiribaltamento in poliamide, finitura nera
- Tappi in polipropilene, finitura nera

### 1. BACKREST:

Fiberglass reinforced polyamide backrest, black finish. Base integrated steel tube backrest, mesh upholstered

### 2. SEAT:

- Plywood seat, foam padded, upholstery
- Polypropylene seat, foam padded, upholstery

### 3. BASE:

- Cantilever base, Ø 25mm steel tube, chromed finish (15µm) or powder coated
- 4 Legs base, Ø 22 mm steel tube, chromed finish (15µm) or powder coated

### 4. CASTORS/FEET:

- Ø 50 mm self-braking castors, or soft self-bracking, Black finish
- Polyamide anti overturning plugs, black finish
- h.61 mm steel and polyamide glides, black finish
- Polypropylene plugs, black finish

### 1. DOSSIER:

Dossier en polyamide renforcé en fibre de verre, finition noir, en résille

### 2. ASSISE:

- Assise en multiplie de bois, rembourrée de mousse, tapissée
- Assise en polypropylène rembourrée de mousse, tapissée

### 3. PIÈTEMENT:

- Piètement luge en tube d'acier Ø 25mm, finition chromé (15µm) ou verni époxy
- Piètement 4 pieds en tube d'acier Ø 22mm, finition chromé (15µm) ou verni époxy

### 4. ROULETTES/PATINS:

- Roulettes Ø 50mm, autofreinantes ou autofreinantes et gommées, finition noir
- Tampons anti renversement en polyamide noir
- Patin en acier et polyamide, h.61mm, finition noir
- Tampons en polypropylène, finition noir

### 1. RÜCKENLEHNE:

Schwarze glasfaserverstärktpolyamid Netz Rückenlehne, mit Integriert lumbalstütze

### 2. SITZ:

- Holzstiz, ausgepolstert mit Polyurethanschaum, mit Bezug
- Polypropylen Sitz, ausgepolstert mit Polyurethanschaum, mit Bezug

### 3. GESTELL:

- Freischwinger Gestell, Ø 25mm Stahlrohr verchromt (15µm) oder pulverbeschichtet
- 4-Fuß Gestell, Ø 22 mm Stahlrohr verchromt (15µm) oder pulverbeschichtet

### 4. ROLLEN/GLEITER:

- Ø 50 mm gebremste, oder weiche gebremste Rollen, schwarz
- Anti Unkippleiter aus Polyamid, schwarz
- h.61mm Stahl und schwarze Polyamid Gleiter
- Polyamid gleiter, schwarz

### 1. RESPALDO:

Respaldo de poliamida cargada en fibra de vidrio, acabado negro o parte posterior de tubo de acero integrada en la base, malla

### 2. ASIENTO:

- Asiento multicapa de madera con espuma, tapizado
- Asiento de polipropileno acolchado con espuma, tapizado

### 3. BASE:

- Base de trineo en tubo de acero de Ø 25 mm, acabado cromado (15µm) o con recubrimiento en polvo
- Base de 4 patas en tubo de acero de Ø 22 mm, acabado cromado (15µm) o con recubrimiento en polvo

### 4. RUEDAS / PIES:

- Ø 50 mm, blandas o autofrenado y blandas, acabado negro
- Tapones antivuelco en poliamida, acabado negro
- Tapones de polipropileno, acabado negro



ID 1111209612

# ECOCHAIR

SCHIENALE MEDIO IN RETE, STRUTTURA IN METALLO, SEDILE IMBOTTITO  
 MEDIUM MESH BACKREST, METAL STRUCTURE, UPHOLSTERED SEAT  
 MOYEN DOSSIER EN RESILLE, STRUCTURE EN METAL, ASSISE REMBOURRÉ  
 NETZ MITTLERE RÜCKENLEHNE, METALGESTELL, GEPOLSTERT SITZ  
 MEDIO RESPALDO EN MALLA, ESTRUCTURA EN METAL, ASIENTO TAPIZADO

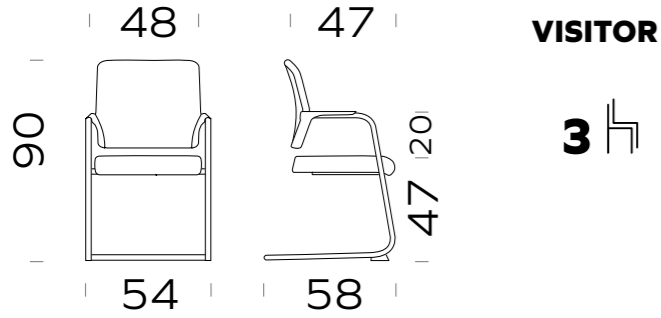

| BASE<br>BASE<br>PIETEMET<br>GESTELL<br>BASE | RUOTA/PIEDINO<br>CASTOR/FEET<br>ROULETTES/PATINS<br>ROLLEN/GLEITER<br>RUEDAS/PIES | SOTTOFAMIGLIA<br>SUBFAMILY<br>SOUS-FAMILLE<br>VARIANTE<br>SUBFAMILIA | STRUTTURA<br>STRUCTURE<br>STRUCTURE<br>STRUKTUR<br>ESTRUCTURA | RETE<br>MESH<br>MAILLE<br>NETZ<br>MALLA | CODICE<br>CODE<br>ARTIKEL<br>CÓDIGO | KG   | TESSUTI/FINITURE<br>UPHOLSTERIES/FINISHING<br>REVETEMENTS<br>STOFFGRUPPE<br>TAPICERÍAS |     |     |     |
|---|---|--|---|---|-------------------------------------|------|--|-----|-----|-----|
|   |   |  |   |   |                                     |      | D  | E   | F   | G   |
|   |   |  |   | M-N                                     | EC0012                              | 9,30 | 384  | 388 | 393 | 433 |
|   |   |  |   | M-N                                     | EC0010                              | 9,30 | 341  | 351 | 355 | 393 |
|   |   |  |   | M-N                                     | EC0006                              | 8,70 | 397  | 403 | 410 | 447 |
|   |   |  |   | M-N                                     | EC0004                              | 8,70 | 360  | 365 | 371 | 410 |

\* DISPONIBILE ANCHE IN  
 ALSO AVAILABLE  
 ÉGALEMENT DISPONIBLE EN  
 ERHÄLTICH AUCH IN  
 TAMBIÉN DISPONIBLE EN



RAL 9016



RAL 1012



RAL 3012



RAL 6021



RAL 7032



RAL 7046

# ECOCHAIR

SCHIENALE MEDIO IN RETE, STRUTTURA IN METALLO, SEDILE IMBOTTITO  
 MEDIUM MESH BACKREST, METAL STRUCTURE, UPHOLSTERED SEAT  
 MOYEN DOSSIER EN RESILLE, STRUCTURE EN METAL, ASSISE REMBOURRÉ  
 NETZ MITTLERE RÜCKENLEHNE, METALGESTELL, GEPOLSTERT SITZ  
 MEDIO RESPALDO EN MALLA, ESTRUCTURA EN METAL, ASIENTO TAPIZADO

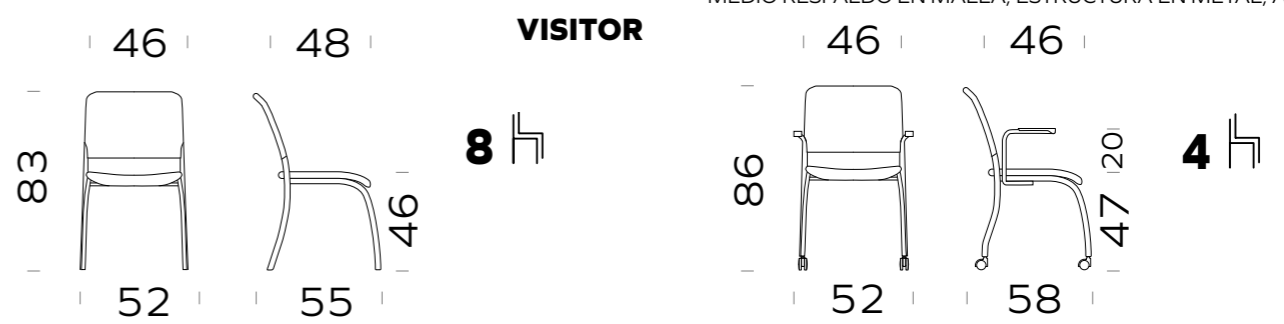

| BASE<br>BASE<br>PIETEMET<br>GESTELL<br>BASE | RUOTA/PIEDINO<br>CASTOR/FEET<br>ROULETTES/PATINS<br>ROLLEN/GLEITER<br>RUEDAS/PIES | STRUTTURA<br>STRUCTURE<br>STRUCTURE<br>STRUKTUR<br>ESTRUCTURA | RETE<br>MESH<br>MAILLE<br>NETZ<br>MALLA | CODICE<br>CODE<br>ARTIKEL<br>CÓDIGO | KG     | TESSUTI/FINITURE<br>UPHOLSTERIES/FINISHING<br>REVETEMENTS<br>STOFFGRUPPE<br>TAPICERÍAS |     |     |     |
|---|---|---|---|-------------------------------------|--------|--|-----|-----|-----|
|   |   |   |   |                                     |        | D  | E   | F   | G   |
|   |   |   | M-N                                     | EC0049                              | 5,40   | 283  | 294 | 300 | 336 |
|   |   |   |   | M-N                                 | EC0046 | 5,40   | 247 | 253 | 257 |
|   |   |   | M-N                                     | EC0051                              | 5,40   | 312  | 318 | 326 | 362 |
|   |   |   |   | M-N                                 | EC0048 | 5,40   | 273 | 279 | 282 |

\* DISPONIBILE ANCHE IN  
 ALSO AVAILABLE  
 ÉGALEMENT DISPONIBLE EN  
 ERHÄLTICH AUCH IN  
 TAMBIÉN DISPONIBLE EN

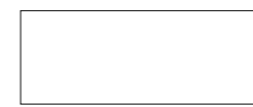

RAL 9016



RAL 1012



RAL 3012



RAL 6021



RAL 7032



RAL 7046











\* DISPONIBILE ANCHE CON  
 ALSO AVAILABLE WITH  
 ÉGALEMENT DISPONIBLE AVEC  
 ERHÄLTICH AUCH MIT  
 TAMBIÉN DISPONIBLE CON

**SAME PRICE**

# ECOCHAIR

## OPTIONALS

### VISITOR

| OPZIONE<br>OPTIONALS<br>OPTIONS<br>OPTIONEN<br>OPCIONES  | VARIANTE<br>VARIANT<br>VARIANTE<br>VARIANTE<br>VARIANTE   | CODICE<br>CODE<br>CODE<br>ARTIKEL<br>CÓDIGO | KG   | PREZZO<br>PRICE<br>PRIX<br>PREIS<br>PRECIO |
|--|---|---|------|--|
|   | <br>Chromed  | <b>XB044</b>                                | 1,60 | 74   |
|  | * <br>RAL 9005   | <b>XB045</b>                                | 1,60 | 61   |
| <b>4</b> <br>ONLY WITH <b>XB044</b><br><b>XB045</b>  | Tavoletta scrittoio destra<br><i>Right-hand writing tablet</i><br>Tablette écritoire droite<br><i>Schreibplatte rechts</i><br>Pala escritorio derecha | <b>XS003</b>                                | 1,30 | 63   |
| <b>3</b> <br>                                      | Tavoletta scrittoio destra<br><i>Right-hand writing tablet</i><br>Tablette écritoire droite<br><i>Schreibplatte rechts</i><br>Pala escritorio derecha | <b>XS005</b>                                | 1,30 | 131  |
|   | Sistema di agganciabilità corta<br><i>Small linking device</i><br>Système d'accrochage court<br><i>Reihenverbindung</i><br>Sistema de enganche corto  | <b>XA003</b>                                | 0,50 | 22   |
|   | Sistema di agganciabilità lunga<br><i>Large linking device</i><br>Système d'accrochage<br><i>Reihenverbindung</i><br>Sistema de enganche largo        | <b>XA004</b>                                | 0,50 | 22   |
|    | Carrello porta sedie<br><i>Chair trolley</i><br>Chariot porte-chaises<br><i>Stapelstuhlwagen</i><br>Carro para transporte de sillas                   | <b>XA009</b>                                | 5,30 | 232  |

\* DISPONIBILE ANCHE IN  
ALSO AVAILABLE  
ÉGALEMENT DISPONIBLE EN  
ERHÄLTlich AUCh IN  
TAMBIÉN DISPONIBLE EN



RAL 9016



RAL 1012



RAL 3012



RAL 6021



RAL 7032



RAL 7046

 MOVING

# DAMA

idea: *Pietro Lovato*



## 1. SCHIENALE:

Schienale in tubo ovale d'acciaio, 30x15mm, finitura verniciata a polvere, in rete o rivestito

## 2. SEDILE:

Sedile in polipropilene imbottito con spugna schiumata a freddo, rivestito

## 3. MECCANISMO:

- SynchronPlus+, comando elevazione a gas, regolazione tensione schienale, inclinazione 20°sch. 8°sed. in 5 posizioni con antishock, traslazione sed. 6cm in 5 posizioni
- Comando elevazione a gas, finitura nera

## 4. GAS:

- Regolabile in altezza, rotazione, finitura cromata
- Regolabile in altezza, rotazione, finitura nera

## 5. BASE:

- Base 5 razze in alluminio, Ø 700mm, finitura lucida
- Base 5 razze in poliamide con carica di fibra di vetro, Ø 680mm, finitura nero
- Base 5 razze design poliamide nera, Ø 700

## 6. RUOTE:

Ruote Ø 50mm, autofrenanti o autofrenanti e gommate, finitura nera

## 7. BRACCIOLI:

- Bracciolo regolabile in poliamide, finitura nera, con top in poliamide, finitura nera, o top in poliuretano morbido
- Bracciolo regolabile in tubo ellittico d'acciaio, 40x20mm, finitura cromata (15µm) o verniciata a polveri, con top in poliamide, finitura nera, o top in poliuretano morbido
- Bracciolo regolabile 4D con top morbido in poliuretano, regolazione 360° silenziosa
- Bracciolo fisso in piatto d'acciaio, 30x5mm, finitura cromata (15µm) rivestito
- Braccioli fissi poliamide

## 1. BACKREST:

Oval steel tube 30x15mm, backrest, powder coated, mesh or upholstered

## 2. SEAT:

Polypropylene seat, cold injected foam padded, upholstery

## 3. MECHANISM:

- SynchronPlus+, gas lift height adj. Backrest tension adj. backrest inclination 20° in 5 locking position with antishock, seat inclination 8°. Sliding seat device 6cm in 5 positions

## 4. GAS LIFT:

- Height adjustable, swivel, chromed finish
- Height adjustable, swivel, Black finish

## 5. BASE:

- Polished aluminium 5 spoke base, Ø 700 mm
- Fiberglass reinforced polyamide 5 spoke base, Ø 680 mm, black finish
- 5-spoke black polyamide design base, Ø 700

## 6. CASTORS:

- Ø 50 mm self-braking castors, or soft self-braking. Black finish

## 7. ARMREST:

- Black Polyamide adj. armrest, black polyamide top or soft black polyurethane pad
- Height adj. Armrest, Ellipt. Steel tube 40x20mm, chromed finish (15µm) or powder coated, polyamide pad, black finish or soft polyurethane pad.
- 4D Armrest, soft polyurethane pad, soundless adjustment 360°
- Steel plate fixed armrest, 30x5mm, chromed finish (15µm), upholstered
- Fixed polyamide armrests

## 1. DOSSIER:

Dossier en tube d'acier ovale, 30x15mm, finition verni époxy, en résille ou tapissé

## 2. ASSISE:

Assise en polypropylène rembourrée de mousse moulée à froids, tapissée

## 3. MECANISME:

- SynchronPlus+, réglage en hauteur, réglage de tension, inclinaison dossier 20°et assise 8°, en 5 positions avec système anti-choc, profondeur d'assise 6 cm en 5 positions

## 4. VERIN A GAZ:

- Réglable en hauteur, pivotant, finition chromé
- Réglable en hauteur, pivotant, finition noir

## 5. PIÈTEMENT:

- Piètement 5 branches alu poli, Ø 700mm
- Piètement 5 branches en polyamide renforcé en fibre de verre, Ø 680mm, finition noir
- Piètement design 5 branches polyamide noir, Ø 700

## 6. ROULETTES:

Roulettes Ø 50mm, autofreinantes ou autofreinantes et gommées, finition noir

## 7. ACCOUDOIR:

- Accoudoir réglable en polyamide, finition noir, manchette en polyamide, finition noir ou en polyuréthane souple
- Accoudoir réglable en tube d'acier elliptique, 40x20mm, finition chromé (15µm) ou verni époxy, manchette en polyamide, finition noir ou en polyuréthane souple
- Accoudoir 4D manchette en polyuréthane souple, pivotant 360°, réglage silencieux
- Accoudoir fixe plat en acier, 30x5mm, finition chromé (15µm) tapissé
- Accoudoirs fixes polyamide

## 1. RÜCKENLEHNE:

Rückenlehne aus pulverbeschichteten Oval-Stahlrohr, 30x15mm, Netzbespannt oder gepolstert

## 2. SITZ:

Polypropylen Sitz, ausgepolstert mit kaltgeschäumten Polyurethan, mit Bezug

## 3. MECHANIK:

- SynchronPlus+, Gaslift Höhenverstellung, Rückenlehne mit Spannungsregler, 20°Rückenlehneigung, 8°Sitzneigung, 5-stufige Einstellung mit Antishock, 6 cm Sitztiefeverstellung mit 5 Positionen

## 4. GASFEDER:

- Sitzhöhenverstellung, drehbar, verchromt
- Sitzhöhenverstellung, drehbar, schwarz

## 5. GESTELL:

- 5-Stern Alu poliertes Fußkreuz, Ø 700 mm
- 5-Stern schwarzes glasfaserverstärktes Polyamid Fußkreuz, Ø 680 mm
- 5-Stern schwarzes Polyamid Design Fußkreuz, Ø 700

## 6. ROLLEN:

Ø 50 mm gebremste, oder weiche gebremste Rollen, schwarz

## 7. ARMLEHNEN:

- Verstellbare schwarze Polyamid Armlehne mit Polyamid Armauflage oder mit weiche Polyurethan Armauflage
- Verstellbare Armlehne aus Ellipt. Stahlrohr, 40x20mm, verchromt (15µm) oder pulverbeschichtet, schwarze Polyamid Armauflage oder weichen Polyurethan
- 4D Armlehne schwarz, PU Armauflage, verschiebbar, geräuschlos 360° drehbar
- Feste Armlehne aus Flachstahl 30x5 mm, verchromt (15µm) Gepolstert
- Ringarmlehnen aus Polyamid

## 1. RESPALDO:

Respaldo de tubo de acero ovalado, 30x15mm, acabado pintado en polvo, con malla o tapizado

## 2. ASIENTO:

Asiento de polipropileno con espuma inyectado a frio, tapizado

## 3. MECANISMO:

- SynchronPlus +, control de elevación de gas, ajuste de tensión posterior, inclinación respaldo 20° . 8° asiento En 5 posiciones con antishock, desplazamiento asiento 6cm en 5 posiciones

## 4. GAS:

- Ajustable en altura, rotación, acabado cromado.
- Ajustable en altura, rotación, acabado negro

## 5. BASE:

- Base de 5 estrellas en aluminio, Ø 700mm, acabado brillante.
- Base de 5 radios en poliamida con carga de fibra de vidrio, Ø 680 mm, acabado negro
- Base design estrella en poliamida negra, Ø 700

## 6. RUEDAS:

Ø 50 mm, blandas o autofrenado y blandas, acabado negro

## 7. BRAZOS:

- Brazos regulable en poliamida, pint. negro, con top de poliamida, acabado negro o top de poliuretano suave
- Brazos ajustables en tubo de acero elíptico, 40x20mm, acabado cromado (15µm) o con recubrimiento en polvo
- Brazos 4D, almohadilla en poliuretano suave, ajuste 360° sin sonido
- Brazos fijo en tubo de acero 30x50mm, acabado cromado, tapizado
- Brazos fijo en poliamida



# DAMA

IMBOTTITA, SUPPORTO LOMBARE REGOLABILE  
UPHOLSTERED, ADJUSTABLE LUMBAR SUPPORT  
REMOURRÉ, SOUTIEN LOMBAIRE RÉGLABLE  
GEPOLSTERT, VERSTELLBARE LUMBALSTÜTZE  
TAPIZADA, SUPORTE LUMBAR REGLABLE

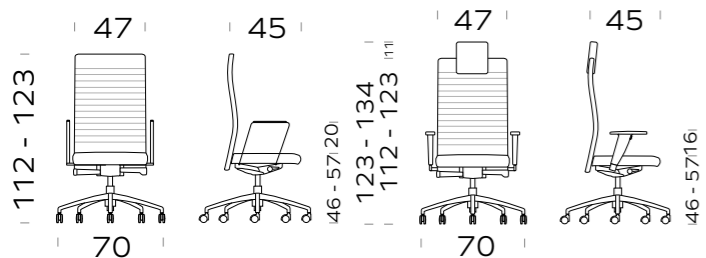

Mechanism: **SynchroPlus**  
TECH INSIDE. SIMPLE OUTSIDE  
Slide

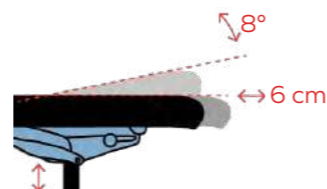

Blocco oscillante, Regolazione altezza/tensione, Regolazione in profondità del sedile  
(Un-)locking device, Height/tension adjustment, Depth adjustment of the seat  
Système de blocage-déblocage de l'oscillation, Réglage en hauteur/ d'intensité, Réglage en profondeur de l'assise  
Blockierung der Rückenlehne / Spannungsregler / Höhenverstellung, Sitztiefenverstellung  
Sistema de bloqueo-desbloqueo del respaldo, Ajuste de altura/tensión, Ajuste de profundidad del asiento

# DAMA R



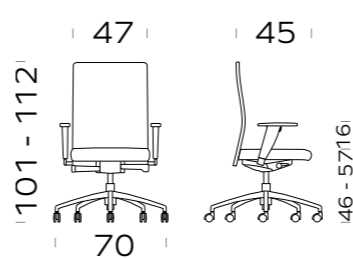



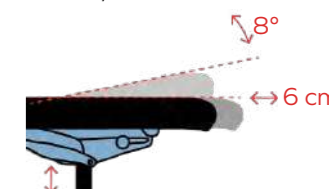

SCHIENALE IN RETE, SUPPORTO LOMBARE REGOLABILE, SEDILE IMBOTTITO  
MESH BACKREST, ADJUSTABLE LUMBAR SUPPORT, UPHOLSTERED SEAT  
DOSSIER EN RÉVILLE, SOUTIEN LOMBAIRE RÉGLABLE, ASSISE REMBOURRÉ  
NETZ RÜCKENLEHNE, VERSTELLBARE LUMBALSTÜTZE, GEPOLSTERT SITZ  
RESPALDO EN MALLA, SUPORTE LUMBAR REGLABLE, ASIENTO TAPIZADO











Mechanism: **SynchroPlus**  
TECH INSIDE. SIMPLE OUTSIDE  
Slide



Blocco oscillante, Regolazione altezza/tensione, Regolazione in profondità del sedile  
(Un-)locking device, Height/tension adjustment, Depth adjustment of the seat  
Système de blocage-déblocage de l'oscillation, Réglage en hauteur/ d'intensité, Réglage en profondeur de l'assise  
Blockierung der Rückenlehne / Spannungsregler / Höhenverstellung, Sitztiefenverstellung  
Sistema de bloqueo-desbloqueo del respaldo, Ajuste de altura/tensión, Ajuste de profundidad del asiento

| BASE<br>BASE<br>PIETEMET<br>GESTELL<br>BASE  | RUOTA/PIEDINO<br>CASTOR/FEET<br>ROULETTES/PATINS<br>ROLLEN/GLEITER<br>RUEDAS/PIES   | STRUTTURA<br>STRUCTURE<br>STRUCTURE<br>STRUKTUR<br>ESTRUCTURA                       | SCHIENALE<br>BACKREST<br>DOSSIER<br>RÜCKENLEHNE<br>RESPALDO | CODICE<br>CODE<br>ARTIKEL<br>CÓDIGO | KG    | TESSUTI/FINITURE<br>UPHOLSTERIES/FINISHING<br>REVETEMENTS<br>STOFFGRUPPE<br>TAPICERIAS |     |     |     |     |
|--|---|---|---|-------------------------------------|-------|--|-----|-----|-----|-----|
|  |   |   |   |                                     |       | D  | E   | F   | G   | H   |
| <br>5 razze in alluminio<br>5-spoke aluminium<br>5 branches alu<br>5 - Stern Alu Fußkreuz<br>estrella en aluminio   |    |    | Medium  | DM0250                              | 12,70 | 615  | 623 | 661 | 719 | 832 |
|  |   |   | High  | DM0137                              | 13,40 | 629  | 635 | 677 | 730 | 934 |
|  |   |   | Medium  | DM0239                              | 12,70 | 615  | 623 | 661 | 719 | 832 |
|  |   |   | High  | DM0129                              | 13,40 | 629  | 635 | 677 | 730 | 934 |
| <br>5 razze poliammide nera<br>5-spoke black polyamide<br>5 branches polyamide noir<br>5 - Stern schwarzes Poyamid Fußkreuz<br>estrella en poliamida negra                                     |   |   | Medium  | DM0244                              | 12,00 | 542  | 547 | 584 | 642 | 755 |
|  |   |   | High  | DM0007                              | 12,70 | 547  | 554 | 591 | 650 | 764 |
| <br>5 razze design poliammide nera<br>5-spoke black polyamide design<br>design 5 branches polyamide noir<br>5 - Stern schwarzes Poyamid Design Fußkreuz<br>design estrella en poliamida negra |  |  | Medium  | DM0301                              | 12,00 | 547  | 554 | 591 | 650 | 764 |
|  |   |   | High  | DM0305                              | 13,40 | 554  | 560 | 595 | 656 | 771 |

| BASE<br>BASE<br>PIETEMET<br>GESTELL<br>BASE  | RUOTA/PIEDINO<br>CASTOR/FEET<br>ROULETTES/PATINS<br>ROLLEN/GLEITER<br>RUEDAS/PIES     | STRUTTURA<br>STRUCTURE<br>STRUCTURE<br>STRUKTUR<br>ESTRUCTURA                         | SCHIENALE<br>BACKREST<br>DOSSIER<br>RÜCKENLEHNE<br>RESPALDO | CODICE<br>CODE<br>ARTIKEL<br>CÓDIGO | KG    | RETE<br>MESH<br>MAILLE<br>NETZ<br>MALLA | TESSUTI/FINITURE<br>UPHOLSTERIES/FINISHING<br>REVETEMENTS<br>STOFFGRUPPE<br>TAPICERIAS |     |     |     |
|--|---|---|---|-------------------------------------|-------|---|--|-----|-----|-----|
|  |   |   |   |                                     |       |   | D  | E   | F   | G   |
| <br>5 razze in alluminio<br>5-spoke aluminium<br>5 branches alu<br>5 - Stern Alu Fußkreuz<br>estrella en aluminio   |    |    | Medium  | DM0284                              | 12,70 | M-N                                     | 526  | 530 | 544 | 573 |
|  |   |   | High  | DM0179                              | 13,40 | M-N                                     | 531  | 535 | 548 | 579 |
|  |   |   | Medium  | DM0273                              | 12,70 | M-N                                     | 526  | 530 | 544 | 573 |
|  |   |   | High  | DM0171                              | 13,40 | M-N                                     | 531  | 535 | 548 | 579 |
| <br>5 razze poliammide nera<br>5-spoke black polyamide<br>5 branches polyamide noir<br>5 - Stern schwarzes Poyamid Fußkreuz<br>estrella en poliamida negra                                     |   |   | Medium  | DM0278                              | 12,00 | M-N                                     | 453  | 456 | 470 | 499 |
|  |   |   | High  | DM0060                              | 12,70 | M-N                                     | 456  | 459 | 471 | 502 |
| <br>5 razze design poliammide nera<br>5-spoke black polyamide design<br>design 5 branches polyamide noir<br>5 - Stern schwarzes Poyamid Design Fußkreuz<br>design estrella en poliamida negra |  |  | Medium  | DM0313                              | 12,00 | M-N                                     | 459  | 461 | 476 | 505 |
|  |   |   | High  | DM0312                              | 12,70 | M-N                                     | 461  | 467 | 479 | 507 |

\* DISPONIBILE ANCHE IN  
ALSO AVAILABLE  
ÉGALEMENT DISPONIBLE EN  
ERHÄLTlich AUCH IN  
TAMBIÉN DISPONIBLE EN



RAL 9016



RAL 6021



RAL 1012



RAL 7032



RAL 3012



RAL 7046

\* DISPONIBILE ANCHE IN  
ALSO AVAILABLE  
ÉGALEMENT DISPONIBLE EN  
ERHÄLTlich AUCH IN  
TAMBIÉN DISPONIBLE EN



RAL 9016



RAL 6021



RAL 1012



RAL 7032















RAL 3012



RAL 7046

# DAMA

## OPTIONALS

| OPZIONE<br>OPTIONS<br>OPTIONEN<br>OPCIONES  | VARIANTE<br>VARIANT<br>VARIANTE<br>VARIANTE   | CODICE<br>CODE<br>CODE<br>ARTIKEL<br>CODIGO | KG   | PREZZO<br>PRICE<br>PRIX<br>PREIS<br>PRECIO | TESSUTI/FINITURE<br>UPHOLSTERIES/FINISHING<br>REVETEMENTS<br>STOFFGRUPPE<br>TAPICERIAS |     |     |     |     |
|---|---|---|------|--|--|-----|-----|-----|-----|
|   |   |   |      |  | D  | E   | F   | G   | H   |
|      | <br>Chromed    | <b>XB001</b>                                | 2,00 | 187  |  |     |     |     |     |
|   | * <br>RAL 9005 | <b>XB105</b>                                | 2,00 | 187  |  |     |     |     |     |
|      | <br>Chromed    | <b>XB002</b>                                | 2,20 |  | 205  | 205 | 205 | 205 | 205 |
|   | * <br>RAL 9005 | <b>XB102</b>                                | 2,20 |  | 205  | 205 | 205 | 205 | 205 |
|      | <b>2D</b>   | <b>XB091</b>                                | 2,50 | 81   |  |     |     |     |     |
| *   | <b>2D</b>   | <b>XB020</b>                                | 1,30 | 39   |  |     |     |     |     |
| *  | <b>2D SOFT</b>  | <b>XB022</b>                                | 1,60 | 61   |  |     |     |     |     |
|    | <b>2D SOFT</b>  | <b>XB094</b>                                | 2,60 | 113  |  |     |     |     |     |
| *  | <b>3D</b>   | <b>XB021</b>                                | 1,30 | 71   |  |     |     |     |     |
| *  | <b>3D SOFT</b>  | <b>XB023</b>                                | 1,60 | 92   |  |     |     |     |     |
|    | <b>3D</b>   | <b>XB092</b>                                | 2,50 | 107  |  |     |     |     |     |

\* DISPONIBILE ANCHE IN  
ALSO AVAILABLE  
ÉGALEMENT DISPONIBLE EN  
ERHÄLTlich AUCH IN  
TAMBIÉN DISPONIBLE EN



RAL 9016



RAL 6021



RAL 1012



RAL 7032



RAL 3012



RAL 7046

# DAMA

## OPTIONALS

| OPZIONE<br>OPTIONS<br>OPTIONEN<br>OPCIONES  | VARIANTE<br>VARIANT<br>VARIANTE<br>VARIANTE   | CODICE<br>CODE<br>CODE<br>ARTIKEL<br>CODIGO | KG   | PREZZO<br>PRICE<br>PRIX<br>PREIS<br>PRECIO | TESSUTI/FINITURE<br>UPHOLSTERIES/FINISHING<br>REVETEMENTS<br>STOFFGRUPPE<br>TAPICERIAS |     |     |     |     |
|---|---|---|------|--|--|-----|-----|-----|-----|
|   |   |   |      |  | D  | E   | F   | G   | H   |
|    | <b>3D SOFT</b>  | <b>XB087</b>                                | 2,50 | 145  |  |     |     |     |     |
| *  | <b>4D EXTRASOFT</b>   | <b>XB089</b>                                | 2,60 | 102  |  |     |     |     |     |
|    | <b>4D EXTRASOFT</b>   | <b>XB090</b>                                | 2,60 | 161  |  |     |     |     |     |
|    | Sedile Comfort<br>Comfort Seats<br>Assise Confort<br>Komfort Sitz<br>Asiento Confortable  | <b>XD018</b>                                | 0,60 | 25   |  |     |     |     |     |
|    | Molle sedile<br>Seat springs<br>Ressorts assise<br>Sitz Federkern<br>Resortes asientos  | <b>XD004</b>                                | 0,80 | 37   |  |     |     |     |     |
|  | SEAT WITH<br>NEGATIVE<br>INCLINATION  | <b>XM007</b>                                | 1,30 | 35   |  |     |     |     |     |
|  | Poggiatesta<br>headrest<br>Appui-tête<br>Kopfstütze<br>Reposacabezas  | <b>XT003</b>                                | 0,80 |  | 97   | 106 | 112 | 121 | 140 |
|  | Poggiatesta regolabile<br>Adjustable headrest<br>Appui-tête réglable<br>Verstellbare Kopfstütze<br>Reposacabezas<br>ajustable           | <b>XT011</b>                                | 0,80 |  | 97   | 97  | 98  | 100 | 116 |
|  | Coprisedile removibile<br>Removable seat cover<br>Housse assise,<br>amovible<br>Sitzbezug, abnehmbar<br>Funda para asiento<br>retirable | <b>FOD193</b>                               |      |  | 36   | 40  | 48  |     |     |

\* DISPONIBILE ANCHE CON  
ALSO AVAILABLE WITH  
ÉGALEMENT DISPONIBLE AVEC  
ERHÄLTlich AUCH MIT  
TAMBIÉN DISPONIBLE CON



d.50 mm autofrenanti  
self-braking d.50mm  
d.50mm autofreinante  
gebremste D.50mm  
diam.50 autofreno

**SAME PRICE**

\* DISPONIBILE ANCHE IN  
ALSO AVAILABLE  
ÉGALEMENT DISPONIBLE EN  
ERHÄLTlich AUCH IN  
TAMBIÉN DISPONIBLE EN



RAL 9016



RAL 6021



RAL 1012



RAL 7032



RAL 3012



RAL 7046

# DAMA Visitor

idea: *Pietro Lovato*

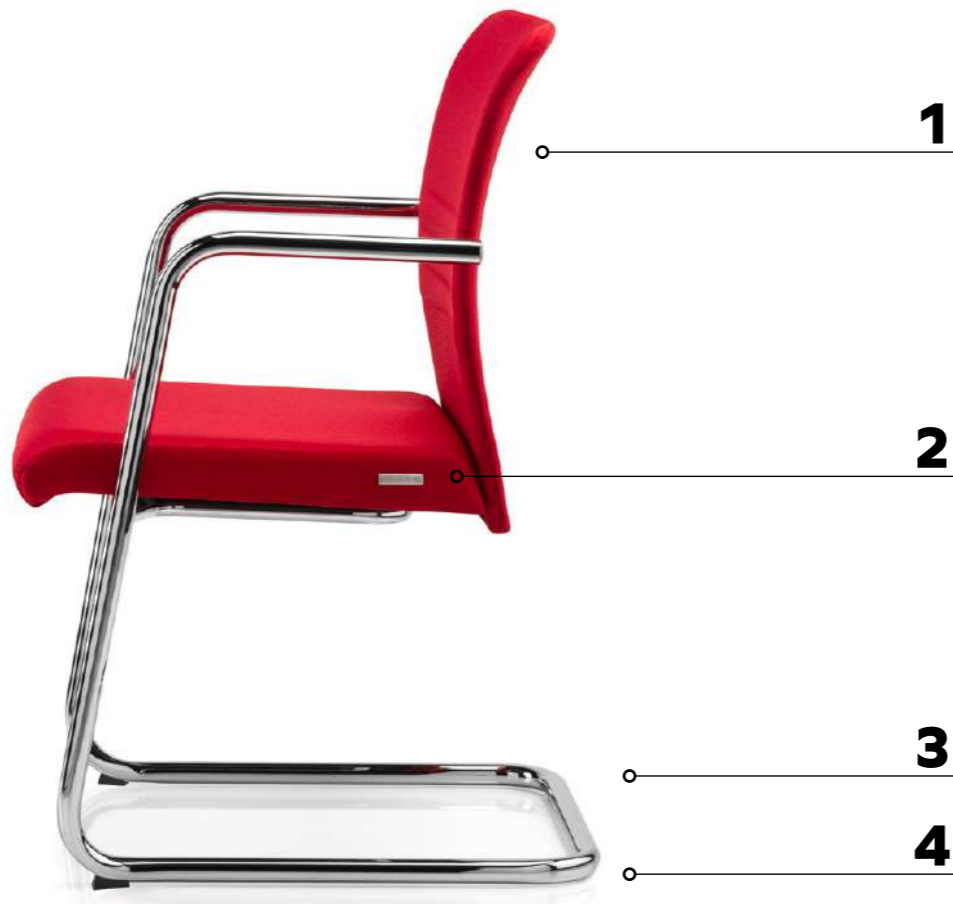

## TECHNICAL INFORMATION

### 1. SCHIENALE:

Schienale in tubo ovale d'acciaio, Ø 20mm, finitura verniciata a polvere, in rete o rivestito

### 2. SEDILE:

Sedile in multistrato di legno con spugna, rivestito

### 3. BASE:

Base a slitta in tubo d'acciaio Ø 25mm, finitura cromata (15µm)

### 4. PIEDINI:

Tappi antiribaltamento in poliamide, finitura nera

### 1. BACKREST:

Oval steel tube Ø 20mm, backrest, powder coated, mesh or upholstered

### 2. SEAT:

Plywood seat, foam padded, upholstery

### 3. BASE:

Cantilever base, Ø 25mm steel tube, chromed finish (15µm)

### 4. FEET:

Polyamide anti overturning plugs, black finish

### 1. DOSSIER:

Dossier en tube d'acier ovale, Ø 20mm, finition verni époxy, en résille ou tapissé

### 2. ASSISE:

Assise en multiplie de bois, rembourrée de mousse, tapissée

### 3. PIÈTEMENT:

Piètement luge en tube d'acier Ø 25mm, finition chromé (15µm)

### 4. PATINS:

Patins anti renversement en polyamide, finition noir

### 1. RÜCKENLEHNE:

Rückenlehne aus Stahlrohr, Ø 20mm, mit Netzbezug oder gepolstert

### 2. SITZ:

Sperrholzsitz gepolstert mit Schaumstoff und Bezug

### 3. GESTELL:

Freischwinger Gestell, Ø 25mm Stahlrohr verchromt (15µm)

### 4. GLEITER:

Anti Unkippleiter aus Polyamid, schwarz

### 1. RESPALDO:

Respaldo de tubo de acero ovalado, Ø 20mm, acabado pintado en polvo, con malla o tapizado

### 2. ASIENTO:

Asiento multicapa de madera con espuma, tapizado

### 3. BASE:

Base de trineo en tubo de acero de Ø 25 mm, acabado cromado (15µm)

### 4. PIES:

Taponos antivuelco en poliamida, acabado negro.

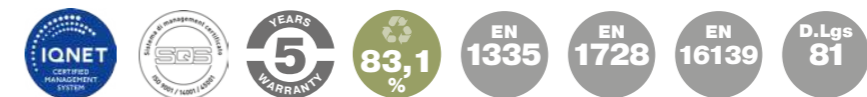

# DAMA

IMBOTTITA, STRUTTURA IN METALLO, SCHIENALE MEDIO  
 UPHOLSTERED, METAL STRUCTURE, MEDIUM BACKREST  
 REMBOURRÉ, STRUCTURE EN METAL, MOYEN DOSSIER  
 GEPOLSTERT, METALSTRUKTUR, MITTLERE RÜCKENLEHNE  
 TAPIZADA, ESTRUCTURA EN METAL, MEDIO RESPALDO

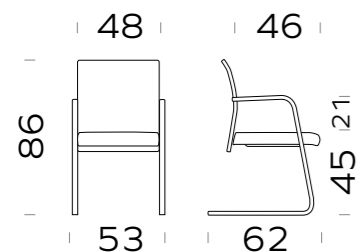

## VISITOR



| BASE<br>BASE<br>PIETEMET<br>GESTELL<br>BASE  | RUOTA/PIEDINO<br>CASTOR/FEET<br>ROULETTES/PATINS<br>ROLLEN/GLEITER<br>RUEDAS/PIES   | STRUTTURA<br>STRUCTURE<br>STRUCTURE<br>STRUKTUR<br>ESTRUCTURA                                      | CODICE<br>CODE<br>CODE<br>ARTIKEL<br>CÓDIGO | KG    | TESSUTI/FINITURE<br>UPHOLSTERIES/FINISHING<br>REVETEMENTS<br>STOFFGRUPPE<br>TAPICERÍAS |     |     |     |     |
|--|---|--|---|-------|--|-----|-----|-----|-----|
|  |   |  |   |       | D  | E   | F   | G   | H   |
| <br>slitta con braccioli<br>cantilever with arms<br>luge avec accoudories<br>Freischwinger mit Armlehnen<br>patin con brazos | <br>neri con feltrini<br>black with felts<br>noirs avec feutres<br>schwarze Filzgleiter<br>negro con fieltro | <br>Chromed       | DM0124                                      | 10,80 | 561  | 570 | 608 | 671 | 788 |
|  |   | <br>RAL 9005<br>* | DM0308                                      | 10,80 | 518  | 527 | 565 | 628 | 745 |

# DAMA R

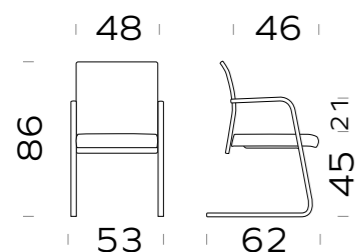
SCHIENALE MEDIO IN RETE, STRUTTURA IN METALLO, SEDILE IMBOTTITO  
 MEDIUM MESH BACKREST, METAL STRUCTURE, UPHOLSTERED SEAT  
 MOYEN DOSSIER EN RESILLE, STRUCTURE EN METAL, ASSISE REMBOURRÉ  
 MITTLERE NETZ RÜCKENLEHNE, METALSTRUKTUR, GEPOLSTERT SITZ  
 MEDIO RESPALDO EN MALLA, ESTRUCTURA EN METAL, ASIENTO TAPIZADO



## VISITOR

| BASE<br>BASE<br>PIETEMET<br>GESTELL<br>BASE  | RUOTA/PIEDINO<br>CASTOR/FEET<br>ROULETTES/PATINS<br>ROLLEN/GLEITER<br>RUEDAS/PIES   | STRUTTURA<br>STRUCTURE<br>STRUCTURE<br>STRUKTUR<br>ESTRUCTURA  | CODICE<br>CODE<br>CODE<br>ARTIKEL<br>CÓDIGO | KG    | RETE<br>MESH<br>RÉSILLE<br>NETZ<br>MALLA | TESSUTI/FINITURE<br>UPHOLSTERIES/FINISHING<br>REVETEMENTS<br>STOFFGRUPPE<br>TAPICERÍAS |     |     |     |
|--|---|--|---|-------|--|--|-----|-----|-----|
|  |   |  |   |       |  | D  | E   | F   | G   |
| <br>slitta con braccioli<br>cantilever with arms<br>luge avec accoudories<br>Freischwinger mit Armlehnen<br>patin con brazos | <br>neri con feltrini<br>black with felts<br>noirs avec feutres<br>schwarze Filzgleiter<br>negro con fieltro | <br>Chromed       | DM0127                                      | 10,80 | M-N                                      | 470  | 472 | 486 | 518 |
|  |   | <br>RAL 9005<br>* | DM0332                                      | 10,80 | M-N                                      | 427  | 429 | 443 | 475 |

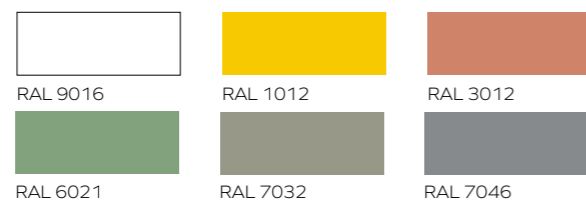

\* DISPONIBILE ANCHE IN  
 ALSO AVAILABLE  
 ÉGALEMENT DISPONIBLE EN  
 ERHÄLTlich AUCh IN  
 TAMBIÉN DISPONIBLE EN



# DAMA

## OPTIONALS

### VISITOR

| OPZIONE<br>OPTIONALS<br>OPTIONS<br>OPCIONEN<br>OPCIONES                             | VARIANTE<br>VARIANT<br>VARIANTE<br>VARIANTE<br>VARIANTE  | CODICE<br>CODE<br>CODE<br>ARTIKEL<br>CÓDIGO | KG   | PREZZO<br>PRICE<br>PRIX<br>PREIS<br>PRECIO | TESSUTI/FINITURE<br>UPHOLSTERIES/FINISHING<br>REVETEMENTS<br>STOFFGRUPPE<br>TAPICERÍAS |    |    |    |
|---|--|---|------|--|--|----|----|----|
|   |  |   |      |  | D  | E  | F  | G  |
|  | <br>RAL 9005<br>* | XH009                                       | 0,20 | 9  |  |    |    |    |
|  | UPHOLSTERED  | XH010                                       | 0,10 |  | 26   | 26 | 26 | 26 |

\* DISPONIBILE ANCHE IN  
 ALSO AVAILABLE  
 ÉGALEMENT DISPONIBLE EN  
 ERHÄLTlich AUCh IN  
 TAMBIÉN DISPONIBLE EN



RAL 9016



RAL 1012



RAL 3012



RAL 6021



RAL 7032



RAL 7046

# FLEXA

idea: *Pietro Lovato*



## 1. SCHIENALE:

Schienale in polipropilene ad alto modulo, a vista, o imbottita con spugna rivestita, con supporto a forma di Y in poliamide con carica di fibra vetro, finitura nera o bianca, con supporto lombare integrato

## 2. SEDILE:

Sedile in polipropilene imbottito con spugna schiumata a freddo rivestito

## 3. MECCANISMO:

SynchroPlus+, comando elevazione a gas, regolazione tensione schienale, inclinazione 20°sch. 8°sed. in 5 posizioni con antishock, traslazione sed. 6cm in 5 posizioni

## 4. GAS:

- Regolabile in altezza, rotazione, finitura cromata
- Regolabile in altezza, rotazione, finitura nera

## 5. BASE:

- Base 5 razze in poliamide con carica di fibra di vetro, Ø 700mm, finitura nero
- Base 5 razze in alluminio, Ø 700mm, finitura lucida
- Base 5 razze in poliamide con carica di fibra di vetro, Ø 680mm, finitura nero
- Base 5 razze design poliamide bianca, Ø 700

## 6. RUOTE:

Ruote Ø 50mm, autofrenanti o autofrenanti e gommate, finitura nera

## 7. BRACCIOLI:

- Bracciolo regolabile in poliamide, finitura nera, con top in poliamide, finitura nera, o top in poliuretano morbido
- Bracciolo regolabile in poliamide, finitura bianca, con top in poliamide, finitura nera, o top in poliuretano morbido
- Bracciolo regolabile in tubo ellittico d'acciaio, 40x20mm, finitura cromata (15µm) o verniciata a polveri, con top in poliamide, finitura nera
- Bracciolo regolabile 4D con top morbido in poliuretano, regolazione 360° silenziosa

## 1. BACKREST:

High modules Polypropylene backrest, optionally foam padded and upholstery. Fiberglass reinforced polyamide Y shaped support. Black or white finishes, integrated lumbar support.

## 2. SEAT:

Polypropylene seat, cold injected foam padded, upholstery

## 3. MECHANISM:

SynchroPlus+, gas lift height adj. Backrest tension adj. backrest inclination 20° in 5 locking position with antishock, seat inclination 8°. Sliding seat device 6cm in 5 positions

## 4. GAS LIFT:

- Height adjustable, swivel, chromed finish
- Height adjustable, swivel, Black finish

## 5. BASE:

- Fiberglass reinforced polyamide 5 spoke base, Ø 700 mm, black finish
- Polished aluminium 5 spoke base, Ø 700 mm
- Fiberglass reinforced polyamide 5 spoke base, Ø 680 mm, black finish
- 5-spoke white polyamide design base, Ø 700

## 6. CASTORS:

Ø 50 mm self-braking castors, or soft self-bracking. Black finish

## 7. ARMREST:

- Black Polyamide adj. armrest, black polyamide top or soft black polyurethane pad
- White Polyamide adj. armrest, black polyamide top or soft black polyurethane pad
- Adj. Armrest, ellipt. Steel tube 40x20, chromed finish (15µm) or powder coated. Black polyamide pad
- 4D Armrest, soft polyurethane pad, soundless adjustment 360°

## 1. DOSSIER:

Dossier en polypropylène haute module, à vue ou rembourré de mousse et tapissé, avec soutien en forme de Y en polyamide renforcé en fibre de verre, finition blanc ou noir, avec soutien lombaire intégré

## 2. ASSISE:

Assise en polypropylène rembourrée de mousse moulée à froid, tapissée

## 3. MECANISME:

SynchroPlus+, réglage en hauteur, réglage de tension, inclinaison dossier 20°et assise 8°, en 5 positions avec système anti-choc, profondeur d'assise 6 cm en 5 positions

## 4. VERIN A GAZ:

- Réglable en hauteur, pivotant, finition chromé
- Réglable en hauteur, pivotant, finition noir

## 5. PIÈTEMENT:

- Piètement 5 branches en polyamide renforcé en fibre de verre, Ø 700mm, finition noir
- Piètement 5 branches alu poli, Ø 700mm
- Piètement 5 branches en polyamide renforcé en fibre de verre, Ø 680mm, finition noir
- Piètement design 5 branches polyamide blanc, Ø 700

## 6. ROULETTES:

Roulettes Ø 50mm, autofrenantes ou autofrenantes et gommées, finition noir

## 7. ACCOUDOIR:

- Accoudoir réglable en polyamide, finition noir, manchette en polyamide, finition noir ou en polyuréthane souple
- Accoudoir réglable en polyamide, finition blanc, manchette en polyamide, finition noir ou en polyuréthane souple
- Accoudoir réglable en tube d'acier elliptique, 40x20mm, finition chromé (15µm) ou verni époxy, manchette en polyamide, finition noir
- Accoudoir 4D manchette en polyuréthane souple, pivotant 360°, réglage silencieux

## 1. RÜCKENLEHNE:

Rückenlehne aus Polypropylen mit hohem Elastizität Modul, alternativ ausgepolstert mit Schwamm und Bezug. Y geformte Rückenlehnenhalter aus glasfaserverstärkten Polypropylen mit integrierte Lumbalstütze schwarz oder weiss.

## 2. SITZ:

Polypropylen Sitz, ausgepolstert mit kaltgeschäumten Polyurethan, mit Bezug

## 3. MECHANIK:

SynchroPlus+, Gaslift Höhenverstellung, Rückenlehne mit Spannungsregler, 20°Rückenlehne - einigung, 8°Sitzneigung, 5-stufige Einstellung mit Antishock, 6 cm Sitztiefenverstellung mit 5 Positionen

## 4. GASFEDER:

- Sitzhöhenverstellung, drehbar, verchromt
- Sitzhöhenverstellung, drehbar, schwarz

## 5. GESTELL:

- 5-Stern glasfaserverstärktpolyamid Fußkreuz, Ø 700 mm, schwarz
- 5-Stern Alu poliertes Fußkreuz, Ø 700 mm
- 5-Stern schwarzes glasfaserverstärktes Polyamid Fußkreuz, Ø 680 mm
- 5-Stern weiß Polyamid Design Fußkreuz, Ø 700

## 6. ROLLEN:

Ø 50 mm gebremste, oder weiche gebremste Rollen, schwarz

## 7. ARMLEHNEN:

- Verstellbare schwarze Polyamid Armlehne mit Polyamid Armaufflage oder mit weiche Polyurethan Armaufflage
- Verstellbare weiße Polyamid Armlehne mit Polyamid Armaufflage oder mit weiche Polyurethan Armaufflage
- Verstellbare Armlehne aus Ellipt. Stahlrohr, 40x20mm, verchromt (15µm) oder pulverbeschichtet, schwarze Polyamid Armaufflage
- 4D Armlehne schwarz, PU Armaufflage, verschiebbar, geräuschlos 360° drehbar

## 1. RESPALDO:

Parte posterior de polipropileno de alto módulo, expuesta o tapizada con espuma cubierta, con soporte en forma de Y en poliamida con relleno de fibra de vidrio, acabado en negro o blanco, con soporte lumbar integrado

## 2. ASIENTO:

Asiento de polipropileno acolchado con espuma de espuma fría, tapizado

## 3. MECANISMO:

SynchroPlus+, control de elevación de gas, ajuste de tensión posterior, inclinación respaldo 20° - 8° asiento En 5 posiciones con antishock, desplazamiento asiento 6cm en 5 posiciones

## 4. GAS:

- Ajustable en altura, rotación, acabado cromado
- Ajustable en altura, rotación, acabado negro

## 5. BASE:

- Base de 5 estrellas en poliamida con carga de fibra de vidrio, Ø 700 mm, acabado negro
- Base de 5 estrellas en aluminio, Ø 700mm, acabado brillante.
- Base de 5 radios en poliamida con carga de fibra de vidrio, Ø 680 mm, acabado negro
- Base design estrella en poliamida blanco, Ø 700

## 6. RUEDAS:

Ruedas de Ø 50 mm, autofrenado o autofrenado blandas, acabado negro

## 7. BRAZOS:

- Brazos regulable en poliamida, pint. negro, con top de poliamida, acabado negro o top de poliuretano suave
- Reposabrazos fijo en poliamida, acabado negro
- Brazos ajustables en tubo de acero elíptico, 40x20mm, acabado cromado (15µm) o con recubrimiento en polvo.
- Brazos 4D, almohadilla en poliuretano suave, ajuste 360° sin sonido

## TECHNICAL INFORMATION



ID 1111210341

# FLEXA

SCHIENALE IN COPOLIMERO, SOSTEGNO Y IN POLIMERO TECNICO, SUPPORTO LOMBARE REGOLABILE  
 COPOLIMER BACKREST, Y SHAPED SUPPORT IN TECNOPOLIMER, ADJUSTABLE LUMBAR SUPPORT  
 DOSSIER EN COPOLYMERE, SOUTIEN À Y EN POLYMÈRE TECHNIQUE, SOUTIEN LOMBAIRE RÉGLABLE  
 POLYP.-COPOLYMER RÜCKENLEHNE, TECHNO-POLYMER Y GEFORMTE RÜCKENLEHNEHALTER,  
 VERSTELLBARE LUMBALSTÜTZE  
 RESPALDO EN COPOLIMERO, ESTRUCTURA Y EN TECNOPOLIMERO, SUPORTE LUMBAR REGLABLE

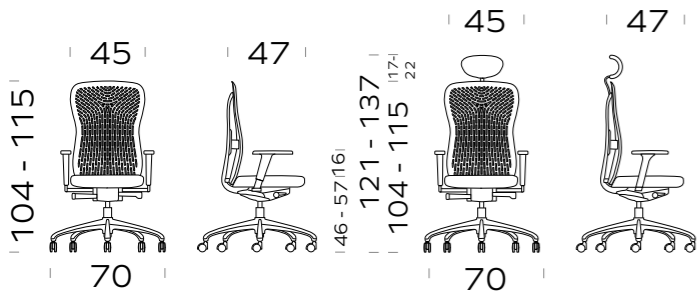

Mechanism: **SynchroPlus**  
 TECH INSIDE. SIMPLE OUTSIDE  
 Slide

Blocco oscillante, Regolazione altezza/tensione, Regolazione in profondità del sedile  
 (Un-latching device, Height/tension adjustment, Depth adjustment of the seat  
 Système de blocage-déblocage de l'oscillation, Réglage en hauteur/ d'intensité, Réglage en profondeur de l'assise  
 Blockierung der Rückenlehne /Spannungsregler / Höhenverstellung, Sitztiefenverstellung  
 Sistema de bloqueo-desbloqueo del respaldo, Ajuste de altura/tensión, Ajuste de profundidad del asiento

| BASE<br>BASE<br>PIETEMET<br>GESTELL<br>BASE  | RUOTA/PIEDINO<br>CASTOR/FEET<br>ROULETTES/PATINS<br>ROLLEN/GLEITER<br>RUEDAS/PIES   | STRUTTURA<br>STRUCTURE<br>STRUCTURE<br>STRUKTUR<br>ESTRUCTURA | CODICE<br>CODE<br>CODE<br>ARTIKEL<br>CÓDIGO | KG    | SCHIENALE<br>BACKREST<br>DOSSIER<br>RÜCKENLEHNE<br>RESPALDO | TESSUTI/FINITURE<br>UPHOLSTERIES/FINISHING<br>REVETEMENTS<br>STOFFGRUPPE<br>TAPICERÍAS |     |     |     |
|--|---|---|---|-------|---|--|-----|-----|-----|
|  |   |   |   |       |   | D  | E   | F   | G   |
| <br>5 razze in alluminio<br>5-spoke aluminium<br>5 branches alu<br>5 - Stern Alu Fußkreuz<br>estrella en aluminio  | <br>d.50mm autofrenanti gomme<br>soft self-braking d.50mm<br>d.50 mm gommées autofreinante<br>weiche gebremste D.50 mm<br>ruedas goma diam.50 autofreno | <br>Chromed   | FL0047                                      | 11,70 | BACKREST<br>RAL   | 407  | 411 | 414 | 447 |
|  |   |   | FL0092                                      | 11,70 | BACKREST<br>RAL   | 407  | 411 | 414 | 447 |
| <br>5 razze poliammide nera<br>5-spoke black polyamide<br>5 branches polyamide noir<br>5 - Stern schwarzes Poyamid Fußkreuz<br>estrella en poliamida negra | <br>d.50mm autofrenanti gomme<br>soft self-braking d.50mm<br>d.50 mm gommées autofreinante<br>weiche gebremste D.50 mm<br>ruedas goma diam.50 autofreno | <br>RAL 9005  | FL0010                                      | 11,10 | BACKREST<br>RAL   | 346  | 348 | 353 | 387 |
|  |   |   | FL0027                                      | 11,20 | BACKREST<br>RAL   | 352  | 355 | 359 | 391 |

| BASE AND Y SUPPORT RAL   | BACKREST RAL |          |          |
|--|--------------|----------|----------|
| * DISPONIBILE ANCHE IN<br>ALSO AVAILABLE<br>ÉGALEMENT DISPONIBLE EN<br>ERHÄLTlich AUCH IN<br>TAMBIÉN DISPONIBLE EN |              |          |          |
|  | RAL 9016     | RAL 1012 | RAL 3012 |
|  |              |          |          |
|  | RAL 6021     | RAL 7032 | RAL 7046 |
|  |              |          |          |
|  | RAL 9005     | RAL 9005 | RAL 9005 |

# FLEXA

## OPTIONALS

| OPZIONE<br>OPTIONALS<br>OPTIONS<br>OPTIONEN<br>OPCIONES | VARIANTE<br>VARIANT<br>VARIANTE<br>VARIANTE<br>VARIANTE  | CODICE<br>CODE<br>CODE<br>ARTIKEL<br>CÓDIGO | KG   | PREZZO<br>PRICE<br>PRIX<br>PREIS<br>PRECIO | TESSUTI/FINITURE<br>UPHOLSTERIES/<br>FINISHING<br>REVETEMENTS<br>STOFFGRUPPE<br>TAPICERÍAS |    |    |    |
|---|--|---|------|--|--|----|----|----|
|   |  |   |      |  | D  | E  | F  | G  |
|   | 2D   | XB091                                       | 2,50 | 81   |  |    |    |    |
|   | 2D SOFT  | XB094                                       | 2,60 | 113  |  |    |    |    |
| *   | 2D   | XB020                                       | 1,30 | 39   |  |    |    |    |
| *   | 2D SOFT  | XB022                                       | 1,60 | 61   |  |    |    |    |
|   | 3D   | XB092                                       | 2,50 | 107  |  |    |    |    |
| *   | 3D   | XB021                                       | 1,30 | 71   |  |    |    |    |
| *   | 3D SOFT  | XB023                                       | 1,60 | 92   |  |    |    |    |
| *   | 4D EXTRASOFT   | XB089                                       | 2,60 | 102  |  |    |    |    |
|   | 4D EXTRASOFT   | XB090                                       | 2,60 | 161  |  |    |    |    |
|   | BACKREST<br>CUSHION  | XC018                                       | 1,20 |  | 63   | 66 | 71 | 77 |
|   | Copri sedile removibile<br>Removable seat cover<br>Housse assise,<br>amovible<br>Sitzbezug, abnehmbar<br>Funda para asiento<br>retirable | FOD144                                      |      |  | 36   | 40 | 48 |    |
|   | Sedile Comfort<br>Comfort Seats<br>Assise Confort<br>Komfort Sitz<br>Asiento Confortable   | XD017                                       | 0,90 | 20   |  |    |    |    |
|   | Molle sedile<br>Seat springs<br>Ressorts assise<br>Sitz Federkern<br>Resortes asientos   | XD005                                       | 0,80 | 37   |  |    |    |    |
|   | SEAT WITH<br>NEGATIVE<br>INCLINATION   | XM007                                       | 1,30 | 35   |  |    |    |    |
|   | Poggiatesta regolabile<br>Adjustable headrest<br>Appui-tête réglable<br>Verstellbare Kopfstütze<br>Reposacabezas<br>ajustable            | XT013                                       | 0,80 |  | 72   | 72 | 73 | 76 |
| *   | Poggiapiedi<br>Footrest<br>Appui-pieds<br>Fußstütze<br>Reposapiés<br>ONLY FOR<br>FL0010  | XP005                                       | 1,10 | 49   |  |    |    |    |

\* DISPONIBILE ANCHE CON  
ALSO AVAILABLE WITH  
ÉGALEMENT DISPONIBLE AVEC  
ERHÄLTlich AUCH MIT  
TAMBIÉN DISPONIBLE CON

**SAME PRICE**

\* DISPONIBILE ANCHE IN  
ALSO AVAILABLE  
ÉGALEMENT DISPONIBLE EN  
ERHÄLTlich AUCH IN  
TAMBIÉN DISPONIBLE EN

|          |          |          |
|----------|----------|----------|
|          |          |          |
| RAL 9016 | RAL 1012 | RAL 3012 |
|          |          |          |
| RAL 6021 | RAL 7032 | RAL 7046 |

## TECHNICAL INFORMATION

### 1. SCHIENALE:

Schienale in poliamide con carica di fibra di vetro

### 2. SEDILE:

Sedile in polipropilene imbottito con spugna, rivestito

### 3. BASE:

- Base a slitta in tubo d'acciaio Ø 25mm, finitura cromata (15µm) o verniciata a polveri
- Base 4 gambe in tubo d'acciaio Ø 25mm, finitura cromata (15µm) o verniciata a polveri

### 1. BACKREST

Fiberglass reinforced polyamide backrest, black finish

### 2. SEAT:

Polypropylene seat, foam padded, upholstery

### 3. BASE:

- Cantilever base, Ø 25mm steel tube, chromed finish (15µm) or powder coated
- 4 Legs base, Ø 25 mm steel tube, chromed finish (15µm) or powder coated

### 1. DOSSIER:

Dossier en polyamide renforcé en fibre de verre

### 2. ASSISE:

Assise en polypropylène rembourrée de mousse, tapissée

### 3. PIÈTEMENT:

- Piètement luge en tube d'acier Ø 25mm, finition chromé (15µm) ou verni époxy
- Piètement 4 pieds en tube d'acier Ø 25mm, finition chromé (15µm) ou verni époxy

### 1. RÜCKENLEHNE

Glasfaserverstärktpolyamid Netz Rückenlehne

### 2. SITZ

Polypropylen Sitz, ausgepolstert mit Polyurethanschaum, mit Bezug

### 3. GESTELL:

- Freischwinger Gestell, Ø 25mm Stahlrohr verchromt (15µm) oder pulverbeschichtet
- 4-Fuß Gestell, Ø 25 mm Stahlrohr verchromt (15µm) oder pulverbeschichtet

### 1. RESPALDO:

Respaldo de poliamida cargado de fibra de vidrio

### 2. ASIENTO:

Asiento de polipropileno acolchado con espuma, tapizado

### 3. BASE:

- Base de trineo en tubo de acero de Ø 25 mm, acabado cromado (15µm) o pintada a polvo
- Base de 4 patas en tubo de acero de Ø 25 mm, acabado cromado (15µm) o pintada a polvo

# FLEXA Visitor

idea: *Pietro Lovato*



ID 1111210200

# FLEXA VISITOR

SCHIENALE MEDIO IN COPOLIMERO, STRUTTURA IN METALLO, SEDILE IMBOTTITO  
 MEDIUM COPOLIMER BACKREST, METAL STRUCTURE, UPHOLSTERED SEAT  
 MOYEN DOSSIER EN COPOLYMÈRE, STRUCTURE EN MÉTAL, ASSISE REMBOURRÉ  
 POLYP.-COPOLYMER RÜCKENLEHNE, METALSTRUKTUR, GEPOLSTERT SITZ  
 CONCHA EN COPOLIMERO, ESTRUCTURA EN METAL, ASIENTO TAPIZADO

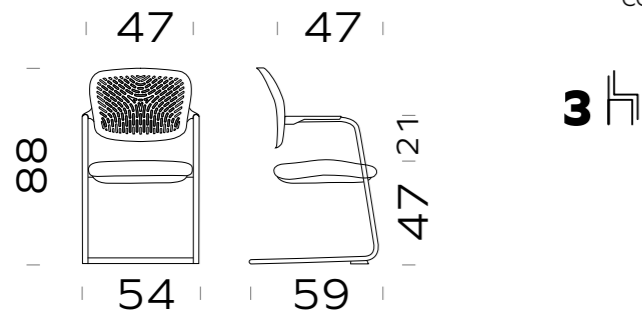

| BASE<br>BASE<br>PIETEMENT<br>GESTELL<br>BASE | RUOTA/PIEDINO<br>CASTOR/FEET<br>ROULETTES/PATINS<br>ROLLEN/GLEITER<br>RUEDAS/PIES | STRUTTURA<br>STRUCTURE<br>STRUCTURE<br>STRUKTUR<br>ESTRUCTURA | CODICE<br>CODE<br>ARTIKEL<br>CÓDIGO | KG   | SCHIENALE<br>BACKREST<br>DOSSIER<br>RÜCKENLEHNE<br>RESPALDO | TESSUTI/FINITURE<br>UPHOLSTERIES/FINISHING<br>REVETEMENTS<br>STOFFGRUPPE<br>TAPICERIAS |     |     |     |
|--|---|---|-------------------------------------|------|---|--|-----|-----|-----|
|  |   |   |                                     |      |   | D  | E   | F   | G   |
|  |   |   | FL0019                              | 7,40 | BACKREST<br>RAL   | 221  | 230 | 234 | 270 |
|  |   |   | FL0016                              | 7,40 | BACKREST<br>RAL   | 182  | 185 | 190 | 223 |

slitta con braccioli  
cantilever with arms  
luge avec accoudoirs  
Freischwinger Gestell mit Armlehnen  
patin con brazos

neri con feltrini  
black with felts  
noirs avec feutres  
schwarze Filzgleiter  
negro con filetro

| OPZIONE<br>OPTIONALS<br>OPTIONS<br>OPTIONEN<br>OPCIONES | VARIANTE<br>VARIANT<br>VARIANTE<br>VARIANTE<br>VARIANTE  | CODICE<br>CODE<br>ARTIKEL<br>CÓDIGO | KG   | PREZZO<br>PRICE<br>PRIX<br>PREIS<br>PRECIO | TESSUTI/FINITURE<br>UPHOLSTERIES/FINISHING<br>REVETEMENTS<br>STOFFGRUPPE<br>TAPICERIAS |    |    |    |
|---|--|-------------------------------------|------|--|--|----|----|----|
|   |  |                                     |      |  | D  | E  | F  | G  |
|   | BACKREST<br>CUSHION  | XC019                               | 0,90 |  | 40   | 44 | 48 | 71 |
|   | Carrello porta sedie<br>Chair trolley<br>Chariot porte-chaises<br>Stapelstuhlwagen<br>Carro para transporte de sillas<br><b>ONLY FOR FL0019<br/>FL0016</b> | XA009                               | 5,30 | 232  |  |    |    |    |

| STRUCTURE RAL  | BACKREST RAL |          |          |
|--|--------------|----------|----------|
| * DISPONIBILE ANCHE IN<br>ALSO AVAILABLE<br>ÉGALEMENT DISPONIBLE EN<br>ERHÄLTlich AUCH IN<br>TAMBIÉN DISPONIBLE EN |              |          |          |
| RAL 9016   | RAL 1012     | RAL 3012 |          |
|  |              |          |          |
| RAL 6021   | RAL 7032     | RAL 7046 | RAL 9005 |

# FLEXA VISITOR

SCHIENALE MEDIO IN COPOLIMERO, STRUTTURA IN METALLO, SEDILE IMBOTTITO  
 MEDIUM COPOLIMER BACKREST, METAL STRUCTURE, UPHOLSTERED SEAT  
 MOYEN DOSSIER EN COPOLYMÈRE, STRUCTURE EN MÉTAL, ASSISE REMBOURRÉ  
 POLYP.-COPOLYMER RÜCKENLEHNE, METALSTRUKTUR, GEPOLSTERT SITZ  
 CONCHA EN COPOLIMERO, ESTRUCTURA EN METAL, ASIENTO TAPIZADO

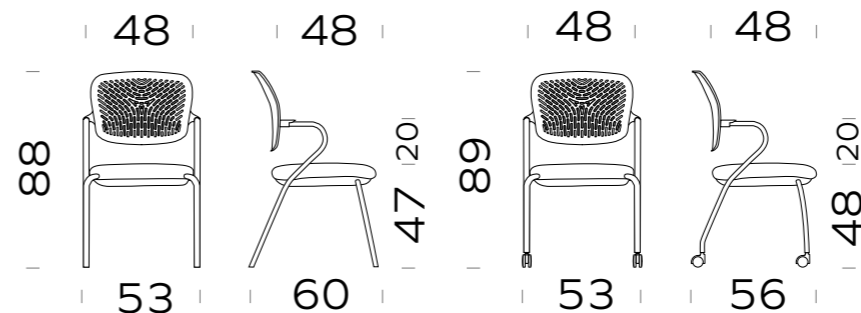

| BASE<br>BASE<br>PIETEMENT<br>GESTELL<br>BASE | RUOTA/PIEDINO<br>CASTOR/FEET<br>ROULETTES/PATINS<br>ROLLEN/GLEITER<br>RUEDAS/PIES | STRUTTURA<br>STRUCTURE<br>STRUCTURE<br>STRUKTUR<br>ESTRUCTURA | CODICE<br>CODE<br>ARTIKEL<br>CÓDIGO | KG   | SCHIENALE<br>BACKREST<br>DOSSIER<br>RÜCKENLEHNE<br>RESPALDO | TESSUTI/FINITURE<br>UPHOLSTERIES/FINISHING<br>REVETEMENTS<br>STOFFGRUPPE<br>TAPICERIAS |     |     |     |
|--|---|---|-------------------------------------|------|---|--|-----|-----|-----|
|  |   |   |                                     |      |   | D  | E   | F   | G   |
|  |   |   | FL0042                              | 6,90 | BACKREST<br>RAL   | 194  | 204 | 210 | 247 |
|  |   |   | FL0041                              | 6,90 | BACKREST<br>RAL   | 153  | 165 | 171 | 210 |
|  |   |   | FL0035                              | 7,10 | BACKREST<br>RAL   | 207  | 218 | 223 | 261 |
|  |   |   | FL0037                              | 7,10 | BACKREST<br>RAL   | 169  | 178 | 185 | 223 |
|  |   |   | FL0037                              | 7,10 | BACKREST<br>RAL   | 169  | 178 | 185 | 223 |

4 gambe  
4-legs  
4 pieds  
4-Fuß Gestell  
4 patas

tappi  
plugs  
patins  
Gleiter  
tapos

d.50 mm autofrenanti gommate  
soft self-braking d.50mm  
d.50mm gommées autofreinante  
weiche gebremste D.50mm  
ruedas goma diam.50 autofreno

| STRUCTURE RAL  | BACKREST RAL |          |          |
|--|--------------|----------|----------|
| * DISPONIBILE ANCHE IN<br>ALSO AVAILABLE<br>ÉGALEMENT DISPONIBLE EN<br>ERHÄLTlich AUCH IN<br>TAMBIÉN DISPONIBLE EN |              |          |          |
| RAL 9016   | RAL 1012     | RAL 3012 |          |
|  |              |          |          |
| RAL 6021   | RAL 7032     | RAL 7046 | RAL 9005 |

\* DISPONIBILE ANCHE CON  
ALSO AVAILABLE WITH  
ÉGALEMENT DISPONIBLE AVEC  
ERHÄLTlich AUCH MIT  
TAMBIÉN DISPONIBLE CON

**SAME PRICE**



**1. SCHIENALE:**

Schienale regolabile in altezza (6 cm) in polipropilene, finitura nera, imbottito con spugna schiumata a freddo rivestita, con supporto in tubo rettangolare d'acciaio, 60x20mm, fin. verniciata a polveri

**2. SEDILE:**

Sedile in polipropilene imbottito con spugna schiumata a freddo, rivestito

**3. MECCANISMO:**

SynchroPlus+, comando elevazione a gas, regolazione tensione schienale, inclinazione 20°sch. 8°sed. in 5 posizioni con antishock, traslazione sed. 6cm in 5 posizioni

**4. GAS:**

- Regolabile in altezza, rotazione, fin. cromata
- Regolabile in altezza, rotazione, finitura nera

**5. BASE:**

- Base 5 razze in alluminio, Ø 700mm, finitura lucida
- Base 5 razze in poliamide con carica di fibra di vetro, Ø 680mm, finitura nero

**6. RUOTE:**

Ruote Ø 50mm, autofrenanti o autofrenanti e gommate, finitura nera

**7. BRACCIOLI:**

- Bracciolo regolabile in poliamide, fin. nera, con top in poliamide, finitura nera, o top in poliuretano morbido
- Bracciolo fisso in poliamide, fin. nera
- Bracciolo regolabile in tubo ellittico d'acciaio, 40x20mm, finitura cromata (15µm) o verniciata a polveri, con top in poliamide, finitura nera
- Bracciolo regolabile 4D con top morbido in poliuretano, regolazione 360° silenziosa

**1. BACKREST:**

Polypropylene height adjustable backrest (6cm), black finish, cold injected foam padded, upholstery. Rect. Steel tube 60x20mm support, powder coated

**2. SEAT:**

Polypropylene seat, cold injected foam padded, upholstery

**3. MECHANISM:**

SynchroPlus+, gas lift height adj. Backrest tension adj. backrest inclination 20° in 5 locking position with antishock, seat inclination 8°. Sliding seat device 6cm in 5 positions

**4. GAS LIFT:**

- Height adjustable, swivel, chromed finish
- Height adjustable, swivel, Black finish

**5. BASE:**

- Polished aluminium 5 spoke base, Ø 700 mm
- Fiberglass reinforced polyamide 5 spoke base, Ø 680 mm, black finish

**6. CASTORS:**

Ø 50 mm self-braking castors, or soft self-bracking. Black finish

**7. ARMREST:**

- Black Polyamide adj. armrest, black polyamide top or soft black polyurethane pad
- Fixed black polyamide arms
- Adj. Armrest, ellipt. Steel tube 40x20, chromed finish (15µm) or powder coated. Black polyamide pad
- 4D Armrest, soft polyurethane pad, soundless adjustment 360°

**1. DOSSIER:**

Dossier réglable en hauteur (6cm) en polypropylène, finition noir, rembourré de mousse moulée à froids et tapissé, avec soutien en tube d'acier rectangulaire, 60x20mm, finition verni époxy

**2. ASSISE:**

Assise en polypropylène rembourrée de mousse moulée à froids, tapissée

**3. MECANISME:**

SynchroPlus+, réglage en hauteur, réglage de tension, inclinaison dossier 20°et assise 8°, en 5 positions avec système anti-choc, profondeur d'assise 6 cm en 5 positions

**4. VERIN A GAZ:**

- Réglable en hauteur, pivotant, finition chromé
- Réglable en hauteur, pivotant, finition noir

**5. PIETEMENT:**

- Piètement 5 branches alu poli, Ø 700mm
- Piètement 5 branches en polyamide renforcé en fibre de verre, Ø 680mm, finition noir

**6. ROULETTES:**

Roulettes Ø 50mm, autofreinantes ou autofreinantes et gommées, finition noir

**7. ACCOUDOIR:**

- Accoudoir réglable en polyamide, finition noir, manchette en polyamide, finition noir ou en polyuréthane souple
- Accoudoir fixe en polyamide, finition noir
- Accoudoir réglable en tube d'acier elliptique, 40x20mm, finition chromé (15µm) ou verni époxy, manchette en polyamide, finition noir
- Accoudoir 4D manchette en polyuréthane souple, pivotant 360°, réglage silencieux

**1. RÜCKENLEHNE:**

(6cm) höhenverst. schwarz Polypropylen Rückenlehne, kaltgeschäumten Polyurethan, mit Bezug, Vierkantstahlrohrstütze 60x20mm, pulverbeschichtet

**2. SITZ:**

Polypropylen Sitz, ausgepolstert mit kaltgeschäumten Polyurethan, mit Bezug

**3. MECHANIK:**

SynchroPlus+, Gaslift Höhenverstellung, Rückenlehne mit Spannungsregler, 20°Rückenlehneigung, 8°Sitzneigung, 5-stufige Einstellung mit Antishock, 6 cm Sitztiefeverstellung mit 5 Positionen

**4. GASFEDER:**

- Sitzhöhenverstellung, drehbar, verchromt
- Sitzhöhenverstellung, drehbar, schwarz

**5. GESTELL:**

- 5-Stern Alu poliertes Fußkreuz, Ø 700 mm
- 5-Stern schwarzes glasfaserverstärktes Polyamid Fußkreuz, Ø 680 mm

**6. ROLLEN:**

Ø 50 mm gebremste, oder weiche gebremste Rollen, schwarz

**7. ARMLEHNEN:**

- Verstellbare schwarze Polyamid Armlehne mit Polyamid Armauflage oder mit weiche
- Polyurethan Armauflage
- Schwarze, feste Polyamid Armlehne
- Feste Armlehne, Ellipt. Stahlrohr, 40x20mm, verchromt (15µm) oder pulverbeschichtet, schwarze Polyamid Armauflage
- 4D Armlehne schwarz, PU Armauflage, verschiebbar, geräuschlos 360° drehbar

**1. RESPALDO:**

Respaldo regulable en altura (6 cm) en polipropileno, acabado negro, acolchado con espuma inyectada a frío, tapizada, con soporte en tubo de acero rectangular, 60x20mm, con recubrimiento en polvo

**2. ASIENTO:**

Asiento de polipropileno acolchado con espuma inyectada fría, tapizada

**3. MECANISMO:**

SynchroPlus+, control de elevación de gas, ajuste de tensión posterior, inclinación respaldo 20°. 8° asiento en 5 posiciones con antishock, desplazamiento asiento 6cm en 5 posiciones

**4. GAS:**

- Adj. En altura, rotación, aleta, cromo
- Adj. En altura, rotación, acabado negro

**5. BASE:**

- Base de 5 estrellas en aluminio, Ø 700mm, acabado pulido.
- Base de 5 radios en poliamida con carga de fibra de vidrio, Ø 680 mm, acabado negro

**6. RUEDAS:**

Ruedas de Ø 50 mm, autofrenado o autofrenado y blandas, acabado negro

**7. BRAZOS:**

- Brazos regulable en poliamida, pint. negro, con top de poliamida, acabado negro o top de poliuretano suave
- Reposabrazos fijo en poliamida, acabado negro
- Brazos ajustables en tubo de acero elíptico, 40x20mm, acabado cromado (15µm) o con recubrimiento en polvo, con top de poliamida, acabado negro
- Brazos 4D, almohadilla en poliuretano suave, ajuste 360° sin sonido



QUESTA COLLEZIONE PER L'ALTO CONTENUTO TECNOLOGICO E INNOVATIVO E' STATA ESPOSTA ALLA IX EDIZIONE

FOR ITS HIGH TECHNOLOGICAL AND INNOVATIVE CONTENT THIS COLLECTION IS EXPOSED AT THE IX EDITION

PRESSO IL MUSEO DELLA SCIENZA E DELLA TECNICA "LEONARDO DA VINCI" -MILANO-

AT THE "LEONARDO DA VINCI" SCIENCE AND TECHNICAL MUSEUM

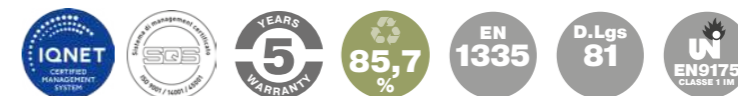

# R&G

IMBOTTITA, SCHIENALE REGOLABILE IN ALTEZZA  
 UPHOLSTERED, ADJUSTABLE BACKREST  
 REMBOURRÉ, DOSSIER RÉGLABLE EN HATEUR  
 GEPOLSTERT, HÖHENVERSTELLUNG RÜCKENLEHNE  
 TAPIZADA, RESPALDO REGLABLE

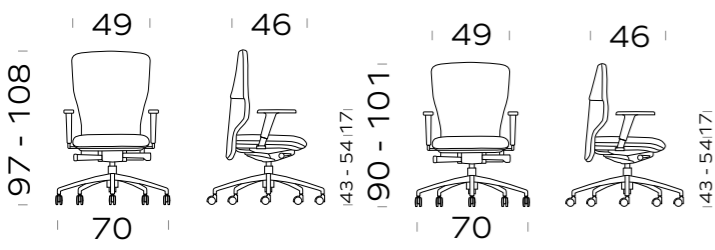

Mechanism: **SynchroPlus**  
 TECH INSIDE, SIMPLE OUTSIDE  
 Slidè

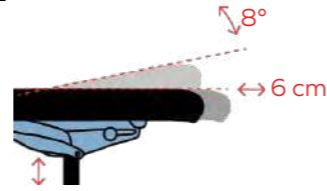

Blocco oscillante, Regolazione altezza/tensione, Regolazione in profondità del sedile  
 (Un-)locking device, Height/tension adjustment, Depth adjustment of the seat  
 Système de blocage-déblocage de l'oscillation, Réglage en hauteur/ d'intensité, Réglage en profondeur de l'assise  
 Blockierung der Rückenlehne /Spannungsregler / Höhenverstellung, Sitztiefenverstellung  
 Sistema de bloqueo-desbloqueo del respaldo, Ajuste de altura/tensión, Ajuste de profundidad del asiento

# R&G

## OPTIONALS

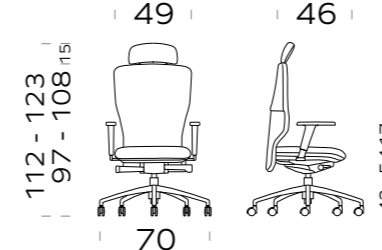

| BASE<br>BASE<br>PIETEMENT<br>GESTELL<br>BASE | RUOTA/PIEDINO<br>CASTOR/FEET<br>ROULETTES/PATINS<br>ROLLEN/GLEITER<br>RUEDAS/PIES | STRUTTURA<br>STRUCTURE<br>STRUCTURE<br>STRUKTUR<br>ESTRUCTURA | SCHIENALE<br>BACKREST<br>DOSSIER<br>RÜCKENLEHNE<br>RESPALDO | CODICE<br>CODE<br>CODE<br>ARTIKEL<br>CÓDIGO | KG    | TESSUTI/FINITURE<br>UPHOLSTERIES/FINISHING<br>REVETEMENTS<br>STOFFGRUPPE<br>TAPICERIAS |     |     |     |
|--|---|---|---|---|-------|--|-----|-----|-----|
|  |   |   |   |   |       | D  | E   | F   | G   |
|  |   | RAL 9005  | Medium  | <b>RG0224</b>                               | 12,60 | 435  | 456 | 469 | 560 |
|  |   |   | High  | <b>RG0090</b>                               | 12,70 | 451  | 468 | 481 | 580 |
|  |   | Chromed   | Medium  | <b>RG0227</b>                               | 13,20 | 543  | 554 | 569 | 661 |
|  |   |   | High  | <b>RG0150</b>                               | 13,40 | 550  | 568 | 580 | 678 |
|  |   | RAL 9005  | Medium  | <b>RG0219</b>                               | 13,20 | 543  | 554 | 569 | 661 |
| High   | <b>RG0145</b>   |   | 13,40   | 550   | 568   | 580  | 678 |     |     |

\* DISPONIBILE ANCHE IN  
 ALSO AVAILABLE  
 ÉGALEMENT DISPONIBLE EN  
 ERHÄLTlich AUCH IN  
 TAMBIÉN DISPONIBLE EN



RAL 9016



RAL 1012



RAL 3012



RAL 6021



RAL 7032



RAL 7046

\* DISPONIBILE ANCHE CON  
 ALSO AVAILABLE WITH  
 ÉGALEMENT DISPONIBLE AVEC  
 ERHÄLTlich AUCH MIT  
 TAMBIÉN DISPONIBLE CON

d.50 mm autofrenanti  
 self-braking d.50mm  
 d.50mm autofreinante  
 gebremste D.50mm  
 diam.50 autofreno

**SAME PRICE**

| OPZIONE<br>OPTIONALS<br>OPTIONS<br>OPTIONEN<br>OPCIONES | VARIANTE<br>VARIANT<br>VARIANTE<br>VARIANTE<br>VARIANTE                                  | CODICE<br>CODE<br>CODE<br>ARTIKEL<br>CÓDIGO | KG   | PREZZO<br>PRICE<br>PRIX<br>PREIS<br>PRECIO | TESSUTI/FINITURE<br>UPHOLSTERIES/FINISHING<br>REVETEMENTS<br>STOFFGRUPPE<br>TAPICERIAS |    |    |     |
|---|--|---|------|--|--|----|----|-----|
|   |  |   |      |  | D  | E  | F  | G   |
|   | 2D   | <b>XB091</b>                                | 2,50 | 81   |  |    |    |     |
|   | 2D SOFT  | <b>XB094</b>                                | 2,60 | 113  |  |    |    |     |
| *   | 2D   | <b>XB020</b>                                | 1,30 | 39   |  |    |    |     |
| *   | 2D SOFT  | <b>XB022</b>                                | 1,60 | 61   |  |    |    |     |
| *   | 3D   | <b>XB021</b>                                | 1,30 | 71   |  |    |    |     |
| *   | 3D SOFT  | <b>XB023</b>                                | 1,60 | 92   |  |    |    |     |
|   | 3D   | <b>XB092</b>                                | 2,50 | 107  |  |    |    |     |
|   | 3D SOFT  | <b>XB087</b>                                | 2,50 | 145  |  |    |    |     |
| *   | 4D EXTRASOFT   | <b>XB089</b>                                | 2,60 | 102  |  |    |    |     |
|   | 4D EXTRASOFT   | <b>XB090</b>                                | 2,60 | 161  |  |    |    |     |
|   | Poggiatesta<br>Headrest<br>Appui-tête<br>Kopfstütze<br>Reposacabezas                     | <b>XT009</b>                                | 0,80 |  | 94   | 98 | 98 | 112 |
|   | Sedile Comfort<br>Comfort Seats<br>Assise Confort<br>Komfort Sitz<br>Asiento Confortable | <b>XD017</b>                                | 0,90 | 20   |  |    |    |     |
|   | SEAT WITH<br>NEGATIVE<br>INCLINATION   | <b>XM007</b>                                | 1,30 | 35   |  |    |    |     |

\* DISPONIBILE ANCHE IN  
 ALSO AVAILABLE  
 ÉGALEMENT DISPONIBLE EN  
 ERHÄLTlich AUCH IN  
 TAMBIÉN DISPONIBLE EN



RAL 9016



RAL 1012



RAL 3012



RAL 6021



RAL 7032



RAL 7046

# OTAVO Q

idea: *Pietro Lovato*



**1. SCHIENALE:**

Schienale in polipropilene in finitura nera, imbottito con spugna e rivestito. Sostegno in tubo rettangolare d'acciaio, 60x20 mm, finitura verniciata a polveri. Supporto lombare regolabile in altezza. Solo con SynchroPlus: schienale regolabile in altezza (6cm)

**2. SEDILE:**

- Sedile in polipropilene imbottito con spugna rivestito (per versione con meccanismo Mini-Synchro)
- Sedile in polipropilene imbottito con spugna schiumata a freddo rivestito (per versione con meccanismo synchroplus)
- Sedile con inclinazione negativa 7°

**3. MECCANISMO:**

- SynchroPlus+, comando elevazione a gas, regolazione tensione schienale, inclinazione 20°sch, 8°sed. in 5 posizioni con antishock, traslazione sed. 6cm in 5 posizioni
- Mini-Synchro, comando elevazione a gas, regolazione tensione dello schienale, inclinazione 18°sch. in 5 posizioni con antishock

**4. GAS:**

Regolabile in altezza, rotazione, fin. nera

**5. BASE:**

- Base 5 razze in poliamide con carica di fibra di vetro, Ø 640mm, finitura nero
- Base 5 razze in poliamide con carica di fibra di vetro, Ø 680mm, finitura nero
- Poggipiedi a pentagono verniciato Ral.

**6. RUOTE:**

Ruote Ø 50mm, autofrenanti o autofrenanti e gommate, finitura nera

**7. BRACCIOLI:**

- Bracciolo fisso in poliamide, fin. nera
- Bracciolo regolabile in poliamide, finitura nera, con top in poliuretano morbido
- Bracciolo regolabile 4D con top morbido in poliuretano, regolazione 360° silenziosa

**1. BACKREST:**

Black polypropylene backrest, foam padded and upholstered. Rectangular steel tube support, 60x20 mm, powder coated finish. Height adjustable lumbar support. Only with SynchroPlus: height adjustable backrest (6cm)

**2. SEAT:**

- Polyprop. seat foam padded with upholstery (for Mini-Synchro mechanism)
- Polyprop. seat, cold injected foam padding with upholstery for SynchroPlus+
- Seat with negative inclination 7°

**3. MECHANISM:**

- SynchroPlus+, gas lift height adj. Backrest tension adj. backrest inclination 20° in 5 locking position with antishock, seat inclination 8°. Sliding seat device 6cm in 5 positions
- Mini-Synchro, gas lift height adj., backrest tension adj. 18°grade with 5 locking position, and antishock

**4. GAS LIFT:**

Height adjustable, swivel, Black finish

**5. BASE:**

- Fiberglass reinforced polyamide 5 spoke base, Ø 640 mm, black finish
- Fiberglass reinforced polyamide 5 spoke base, Ø 680 mm, black finish
- Ral painted pentagon footrest.

**6. CASTORS:**

Ø 50 mm self-braking castors, or soft self-bracking. Black finish

**7. ARMREST:**

- Fixed polyamide armrest, black finish
- Black Polyamide adj. armrest, black polyamide top or soft black polyurethane pad
- 4D Armrest, soft polyurethane pad, soundless adjustment 360°

**1. DOSSIER:**

Dossier en polypropylène finition noir, rembourré en mousse et revêtu. Support en tube d'acier rectangulaire, 60x20mm, finition époxy noir. Soutien lombaire réglable en hauteur. Version SynchroPlus: dossier réglable en hauteur (6 cm)

**2. ASSISE:**

- Assise en polypropylène rembourrée de mousse et tapissée (pour version mécanisme Mini-Synchro)
- Assise en polypropylène rembourrée de mousse moulée à froid et tapissée (pour version mécanisme SynchroPlus+)
- Assise avec inclinaison négative de 7°

**3. MÉCANISME:**

- SynchroPlus+, réglage en hauteur, réglage de tension, inclinaison dossier 20°et assise 8°, en 5 positions avec système anti-choc, profondeur d'assise 6 cm en 5 positions
- Mini-Synchro, réglage en hauteur, réglage de tension, inclinaison dossier 18°en 5 positions avec système antichoc

**4. VERIN A GAZ:**

Réglable en hauteur, pivotant, finition noir

**5. PIÈTEMENT:**

- Piètement 5 branches en polyamide renforcé en fibre de verre, Ø 640mm, finition noir
- Piètement 5 branches en polyamide renforcé en fibre de verre, Ø 680mm, finition noir
- Repose-pieds pentagonal peint selon le nuancier RAL.

**6. ROULETTES:**

Roulettes Ø 50mm, autofreinantes ou autofreinantes et gommées, finition noir

**7. ACCOUDOIR:**

- Accoudoir fixe en polyamide, finition noir
- Accoudoir réglable en polyamide, finition noir, manchette en polyuréthane souple
- Accoudoir 4D manchette en polyuréthane souple, pivotant 360°, réglage silencieux

**1. RÜCKENLEHNE:**

Rückenlehne aus schwarzen Polypropylen mit Schaumstoff ausgepolstert und überzogen. Rechteckige pulverbeschichtete Stahlstütze, 60x20mm. Höhenverstellbare Lumbalstütze. Höhenverstellbare Rückenlehne (6 cm), nur mit SynchroPlus-Mechanik

**2. SITZ:**

- Polypropylen Sitz mit Schaumstoff ausgepolstert und mit Bezug. (Mit Mini-Synchro Mechanik)
- Polypropylen Sitz mit kalgeschäumten Polyurethan Schaum mit Bezug. (Mit SynchroPlus-Mechanik)
- Sitzfläche mit negativer Neigung von 7°

**3. MECHANIK:**

- SynchroPlus+, Gaslift Höhenerstellung, Rückenlehne mit Spannungsregler, 20°Rückenehneigung, 8°Sitzneigung, 5-stufige Einstellung mit Antishock, 6 cm Sitztiefenverstellung mit 5 Positionen
- Mini-Synchro, Gaslift Höhenerstellung, Rückenlehne mit Spannungsregler, 18°Rückenehneigung mit 5-stufige Stoßdämpfung

**4. GASFEDER:**

Sitzhöhenverstellung, drehbar, schwarz

**5. GESTELL:**

- 5-Stern schwarzes glasfaserverstärktes Polyamid Fußkreuz, Ø 640 mm
- 5-Stern schwarzes glasfaserverstärktes Polyamid Fußkreuz, Ø 680 mm
- Fünfeckige Fußstütze, lackiert nach RAL.

**6. ROLLEN:**

Ø 50 mm gebremste, oder weiche gebremste Rollen, schwarz

**7. ARMLEHNEN:**

- Schwarze, feste Polyamid Armlehne
- Verstellbare schwarze Polyamid Armlehne mit Polyamid Armauflage oder mit weiche Polyurethan Armauflage
- 4D Armlehne schwarz, PU Armauflage, verschiebbar, geräuschlos 360° drehbar

**1. RESPALDO:**

Respaldo de polipropileno con acabado negro, acolchado con espuma y tapizado. Soporte de tubo rectangular de acero, 60x20 mm, acabado con pintura a polvo. Soporte lumbar ajustable en altura. Solo con SynchroPlus: respaldo ajustable en altura (6cm)

**2. ASIENTO:**

- Asiento de polipropileno tapizado con una espuma cubierta (para la versión con mecanismo Mini-Synchro)
- Asiento de polipropileno acolchado con espuma fría tapizada (para la versión con mecanismo SynchroPlus)
- Asiento con inclinación negativa de 7°

**3. MECANISMO:**

- SynchroPlus+, control de elevación de gas, ajuste de tensión posterior, inclinación respaldo 20°. 8° asiento En 5 posiciones con antishock, desplazamiento asiento 6cm en 5 posiciones.
- Mini-Synchro, control de elevación de gas, ajuste de tensión posterior, inclinación de 18° respaldo. en 5 posiciones con antishock

**4. GAS:**

Ajustable en altura, rotación, alea, negro

**5. BASE:**

- Base de 5 estrellas en poliamida con carga de fibra de vidrio, Ø 640 mm, acabado negro
- Base de 5 radios en poliamida con carga de fibra de vidrio, Ø 680 mm, acabado negro
- Reposapiés pentagonal pintado según carta RAL.

**6. RUEDAS:**

Ruedas de Ø 50 mm, autofrenado o autofrenado y blandas, acabado negro

**7. BRAZOS:**

- Brazos fijo en poliamida, pint. negro
- Brazos ajustables en poliamida, acabado negro, con top de poliamida, acabado negro o top de poliuretano suave
- Brazos 4D, almohadilla en poliuretano suave, ajuste 360° sin sonido



# OTAVO Q

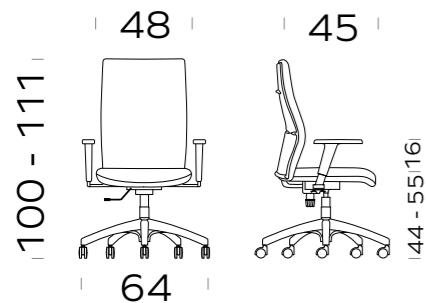

IMBOTTITA, SUPPORTO LOMBARE REGOLABILE  
UPHOLSTERED, ADJUSTABLE LUMBAR SUPPORT  
REMOURRÉ, SOUTIEN LOMBAIRE RÉGLABLE  
GEPOLSTERT, VERSTELLBARE LUMBALSTÜTZE  
TAPIZADA, SUPORTE LUMBAR REGLABLE

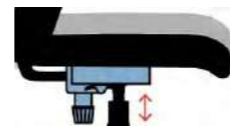

Mechanism: **MiniSynchro**



Blocco oscillante, Regolazione tensione dello schienale  
(Un-)locking device, backrest tension adjustment  
Système de blocage-déblocage de l'oscillation, Réglage d'intensité du dossier  
Blockierung der Rückenlehnen / Spannungsregler  
Sistema de bloqueo-desbloqueo del respaldo, Ajuste de tensión

| BASE<br>BASE<br>PIETEMENT<br>GESTELL<br>BASE  | RUOTA/PIEDINO<br>CASTOR/FEET<br>ROULETTES/PATINS<br>ROLLEN/GLEITER<br>RUEDAS/PIES  | SCHIENALE<br>BACKREST<br>DOSSIER<br>RÜCKENLEHNE<br>RESPALDO | STRUTTURA<br>STRUCTURE<br>STRUCTURE<br>STRUKTUR<br>ESTRUCTURA                                      | CODICE<br>CODE<br>ARTIKEL<br>CÓDIGO | KG    | TESSUTI/FINITURE<br>UPHOLSTERIES/FINISHING<br>REVETEMENTS<br>STOFFGRUPPE<br>TAPICERÍAS |     |     |     |
|---|--|---|--|-------------------------------------|-------|--|-----|-----|-----|
|   |  |   |  |                                     |       | D  | E   | F   | G   |
| <br>5 razze poliammide<br>5-spoke polyamide<br>5-branches polyamide<br>5-Stern Polyamid Fußkreuz<br>estrella en poliamida |  *<br>d.50mm autofrenanti gommate<br>soft self-braking d.50mm<br>d.50 mm gommées autofreinante<br>weiche gebremste D.50 mm<br>ruedas goma diam.50 autofreno | Standard  | <br>RAL 9005<br>* | <b>OT0127</b>                       | 12,40 | 335  | 346 | 353 | 425 |

\* DISPONIBILE ANCHE IN  
ALSO AVAILABLE  
ÉGALEMENT DISPONIBLE EN  
ERHÄLTlich AUCH IN  
TAMBIÉN DISPONIBLE EN



RAL 9016



RAL 1012



RAL 3012



RAL 6021



RAL 7032



RAL 7046

# OTAVO Q

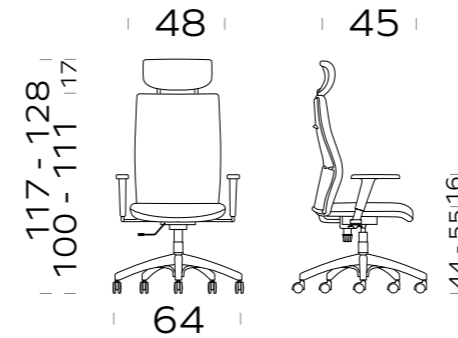

IMBOTTITA, SUPPORTO LOMBARE REGOLABILE  
UPHOLSTERED, ADJUSTABLE LUMBAR SUPPORT  
REMOURRÉ, SOUTIEN LOMBAIRE RÉGLABLE  
GEPOLSTERT, VERSTELLBARE LUMBALSTÜTZE  
TAPIZADA, SUPORTE LUMBAR REGLABLE

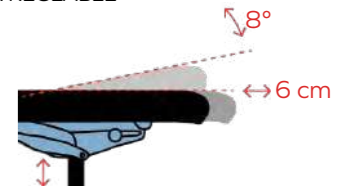

Mechanism: **SynchroPlus**  
Slide



Blocco oscillante, Regolazione altezza/tensione dello schienale, Regolazione in profondità del sedile  
(Un-)locking device, Backrest height/tension adjustment, Depth adjustment of the seat  
Système de blocage-déblocage de l'oscillation, Réglage en hauteur/ d'intensité du dossier,  
Réglage en profondeur de l'assise  
Blockierung der Rückenlehne / Spannungsregler / Höhenverstellbar, Sitztiefenverstellung  
Sistema de bloqueo-desbloqueo del respaldo, Ajuste de altura/tensión, Ajuste de profundidad del asiento

| BASE<br>BASE<br>PIETEMENT<br>GESTELL<br>BASE   | RUOTA/PIEDINO<br>CASTOR/FEET<br>ROULETTES/PATINS<br>ROLLEN/GLEITER<br>RUEDAS/PIES  | SCHIENALE<br>BACKREST<br>DOSSIER<br>RÜCKENLEHNE<br>RESPALDO  | STRUTTURA<br>STRUCTURE<br>STRUCTURE<br>STRUKTUR<br>ESTRUCTURA  | CODICE<br>CODE<br>ARTIKEL<br>CÓDIGO | KG    | TESSUTI/FINITURE<br>UPHOLSTERIES/FINISHING<br>REVETEMENTS<br>STOFFGRUPPE<br>TAPICERÍAS |     |     |     |
|--|--|--|--|-------------------------------------|-------|--|-----|-----|-----|
|  |  |  |  |                                     |       | D  | E   | F   | G   |
| <br>5 razze poliammide<br>5-spoke polyamide<br>5-branches polyamide<br>5-Stern Polyamid Fußkreuz<br>estrella en poliamida |  *<br>d.50mm autofrenanti gommate<br>soft self-braking d.50mm<br>d.50 mm gommées autofreinante<br>weiche gebremste D.50 mm<br>ruedas goma diam.50 autofreno | Regolabile in<br>altezza<br>Adjustable<br>backrest<br>Réglable en hauteur<br>Höhenverstellbare<br>Rückenlehne<br>Respaldo<br>reglable en<br>altura | <br>RAL 9005<br>* | <b>OT0346</b>                       | 13,00 | 414  | 426 | 437 | 505 |

\* DISPONIBILE ANCHE IN  
ALSO AVAILABLE  
ÉGALEMENT DISPONIBLE EN  
ERHÄLTlich AUCH IN  
TAMBIÉN DISPONIBLE EN



RAL 9016



RAL 1012



RAL 3012



RAL 6021



RAL 7032



RAL 7046

# OTAVO R

idea: *Pietro Lovato*



## 1. SCHIENALE:

Schienale in tubo tondo d'acciaio, Ø 20 mm, finitura vern. a polveri rivestito in rete. Supporto lombare regolabile in altezza.

## 2. SEDILE:

- Sedile in polipropilene imbottito con spugna rivestito (per versione con meccanismo Mini-Synchro)
- Sedile in polipropilene imbottito con spugna schiumata a freddo rivestito (per versione con meccanismo Synchro - Plus+)

## 3. MECCANISMO:

- SynchroPlus+, comando elevazione a gas, regolazione tensione schienale, inclinazione 20°sch. 8°sed. in 5 posizioni con antishock, traslazione sed. 6cm in 5 posizioni
- Mini-Synchro, comando elevazione a gas, regolazione tensione dello schienale, inclinazione 18°sch. in 5 posizioni con antishock

## 4. GAS:

Regolabile in altezza, rotazione, fin. nera

## 5. BASE:

- Base 5 razze in poliamide con carica di fibra di vetro, Ø 640mm, finitura nero
- Base 5 razze in poliamide con carica di fibra di vetro, Ø 680mm, finitura nero

## 6. RUOTE:

Ruote Ø 50mm, autofrenanti o autofrenanti e gommate, finitura nera

## 7. BRACCIOLI:

- Bracciolo fisso in poliamide, finitura nera
- Bracciolo regolabile in poliamide, finitura nera, con top in poliuretano morbido
- Bracciolo regolabile 4D con top morbido in poliuretano, regolazione 360° silenziosa

## 1. BACKREST:

Ø 20mm steel round bar backrest, powder coated, mesh. Height adjustable lumbar support

## 2. SEAT:

- Polyprop. seat foam padded with upholstery (for Mini-Synchro mechanism)
- Polyprop. Seat, cold injected foam padding with upholstery for SynchroPlus+

## 3. MECHANISM:

- SynchroPlus+, gas lift height adj., Backrest tension adj., backrest inclination 20° in 5 locking position with antishock, seat inclination 8°. Sliding seat device 6cm in 5 positions
- Mini-Synchro, gas lift height adj., backrest tension adj., 18°grade with 5 locking position, and antishock

## 4. GAS LIFT:

Height adjustable, swivel, Black finish

## 5. BASE:

- Fiberglass reinforced polyamide 5 spoke base, Ø 640 mm, black finish
- Fiberglass reinforced polyamide 5 spoke base, Ø 680 mm, black finish

## 6. CASTORS:

Ø 50 mm self-braking castors, or soft self-braking. Black finish

## 7. ARMREST:

- Fixed polyamide armrest, black finish
- Black Polyamide adj. armrest, black polyamide top or soft black polyurethane pad
- 4D Armrest, soft polyurethane pad, soundless adjustment. 360°

## 1. DOSSIER:

Dossier en tube d'acier rond, Ø 20mm, finition verni époxy, revêtu en résille. Soutien lombaire réglable en hauteur.

## 2. ASSISE:

- Assise en polypropylène rembourrée de mousse et tapis-sée (pour version mécanisme Mini-Synchro)
- Assise en polypropylène rembourrée de mousse moulée à froids et tapissée (pour version mécanisme Synchro - Plus+)

## 3. MECANISME:

- SynchroPlus+, réglage en hauteur, réglage de tension, inclinaison dossier 20°et assise 8°, en 5 positions avec système anti-choc, profondeur d'assise 6 cm en 5 positions
- Mini-Synchro, réglage en hauteur, réglage de tension, inclinaison dossier 18°en 5 positions avec système antichoc

## 4. VERIN A GAZ:

Réglable en hauteur, pivotant, finition noir

## 5. PIETEMENT:

- Piètement 5 branches en polyamide renforcé en fibre de verre, Ø 640mm, finition noir
- Piètement 5 branches en polyamide renforcé en fibre de verre, Ø 680mm, finition noir

## 6. ROULETTES:

Roulettes Ø 50mm, autofreinantes ou autofreinantes et gommées, finition noir

## 7. ACCOUDOIR:

- Accoudoir fixe en polyamide, finition noir
- Accoudoir réglable en polyamide, finition noir, manchette en polyamide, finition noir ou en polyuréthane souple
- Accoudoir 4D manchette en polyuréthane souple, pivotant 360°, réglage silencieux

## 1. RÜCKENLEHNE:

Ø20mm Stahlrohr Rückenlehne pulverbeschichtet, Netz. Höhenverstellbare Lumbalstütze.

## 2. SITZ:

- Polypropylen Sitz mit Schwamm gepolstert und mit Bezug. (Mit Mini-Synchro Mechanik)
- Polypropylen Sitz mit kalteschäumten Polyurethan Schaum mit Bezug. (Mit SynchroPlus+ Mechanik)

## 3. MECHANIK:

- SynchroPlus+, Gaslift Höhenverstellung, Rückenlehne mit Spannungsregler, 20°Rückenlehneigung, 8°Sitzneigung, 5-stufige Einstellung mit Antishock, 6 cm Sitztiefenverstellung mit 5 Positionen
- Mzz, Gaslift Höhenverstellung, Rückenlehne mit Spannungsregler, 18°Rückenlehneigung mit 5-stufige Stoßdämpfung.

## 4. GASFEDER:

Sitzhöhenverstellung, drehbar, schwarz

## 5. GESTELL:

- Stern schwarzes glasfaserverstärktes Polyamid Fußkreuz, Ø 640 mm
- 5-Stern schwarzes glasfaserverstärktes Polyamid Fußkreuz, Ø 680 mm

## 6. ROLLEN:

Ø 50 mm gebremste, oder weiche gebremste Rollen, schwarz

## 7. ARMLEHNEN:

- schwarze, feste Polyamide Armlehne
- Verstellbare schwarze Polyamid Armlehne mit Polyamid Armauflage oder mit weiche Polyurethan Armauflage
- 4D Armlehne schwarz, PU Armauflage, verschiebbar, geräuschlos 360° drehbar

## 1. RESPALDO:

Respaldo en tubo de acero redondo, Ø 20 mm, acabado pintado polvo cubierto con malla. Soporte lumbar ajustable en altura.

## 2. ASIENTO:

- Asiento de polipropileno tapizado con una espuma cubierta fría cubierta (para la versión con mecanismo Mini-Synchro)
- Asiento de polipropileno acolchado con espuma inyectada fría cubierta (para la versión con mecanismo SynchroPlus+)

## 3. MECANISMO:

- SynchroPlus+, control de elevación de gas, ajuste de tensión posterior, inclinación respaldo 20°. 8° asiento En 5 posiciones con antishock, desplazamiento asiento 6cm en 5 posiciones.
- Mini-Synchro, control de elevación de gas, ajuste de tensión posterior, inclinación de 18° respaldo, en 5 posiciones con antishock

## 4. GAS:

Ajustable en altura, rotación, acabado negro

## 5. BASE:

- Base de 5 estrellas en poliamida con carga de fibra de vidrio, Ø 640 mm, acabado negro
- Base de 5 radios en poliamida con carga de fibra de vidrio, Ø 680 mm, acabado negro

## 6. RUEDAS:

Ruedas de Ø 50 mm, autofrenado o autofrenado y blandas, acabado negro

## 7. BRAZOS:

- Brazos fijo en poliamida, acabado negro
- Brazos ajustables en poliamida, acabado negro, con top de poliamida, acabado negro o top de poliuretano suave
- Brazos 4D, almohadilla en poliuretano suave, ajuste 360° sin sonido



# OTAVO R

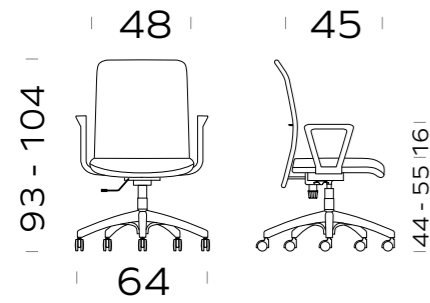

SCHIENALE IN RETE, SUPPORTO LOMBARE REGOLABILE  
 MESH BACKREST, ADJUSTABLE LUMBAR SUPPORT  
 DOSSIER EN RÉVILLE, SOUTIEN LOMBAIRE RÉGLABLE  
 NETZ RÜCKENLEHNE, VERSTELLBARE LUMBALSTÜTZE  
 RESPALDO EN MALLA, SUPORTE LUMBAR REGLABLE

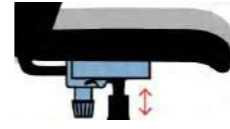

Mechanism: **MiniSynchro**



Blocco oscillante, Regolazione tensione dello schienale  
 (Un-)locking device, backrest tension adjustment  
 Système de blocage-déblocage de l'oscillation, Réglage d'intensité du dossier  
 Blockierung der Rückenlehnen / Spannungsregler  
 Sistema de bloqueo-desbloqueo del respaldo, Ajuste de tensión

| BASE<br>BASE<br>PIETEMENT<br>GESTELL<br>BASE  | RUOTA/PIEDINO<br>CASTOR/FEET<br>ROULETTES/PATINS<br>ROLLEN/GLEITER<br>RUEDAS/PIES  | STRUTTURA<br>STRUCTURE<br>STRUCTURE<br>STRUKTUR<br>ESTRUCTURA                                       | CODICE<br>CODE<br>CODE<br>ARTIKEL<br>CÓDIGO | KG    | RETE<br>MESH<br>RESILLE<br>NETZ<br>MALLA | TESSUTI/FINITURE<br>UPHOLSTERIES/FINISHING<br>REVETEMENTS<br>STOFFGRUPPE<br>TAPICERÍAS |     |     |     |
|---|--|---|---|-------|--|--|-----|-----|-----|
|   |  |   |   |       |  | D  | E   | F   | G   |
| <br><br>5 razze poliammide<br>5-spoke polyamide<br>5-branches polyamide<br>5-Stern Polyamid Fußkreuz<br>estrella en polyamida |  *<br><br>d.50mm autofrenanti gommata<br>soft self-braking d.50mm<br>d.50 mm gommées autofreinante<br>weiche gebremste D.50 mm<br>ruedas goma diam.50 autofreno |  *<br><br>RAL 9005 | <b>OT0147</b>                               | 11,10 | M-N                                      | 359  | 365 | 372 | 407 |

\* DISPONIBILE ANCHE IN  
 ALSO AVAILABLE  
 ÉGALEMENT DISPONIBLE EN  
 ERHÄLTlich AUCh IN  
 TAMBIÉN DISPONIBLE EN



RAL 9016



RAL 1012



RAL 3012



RAL 6021



RAL 7032



RAL 7046

# OTAVO R

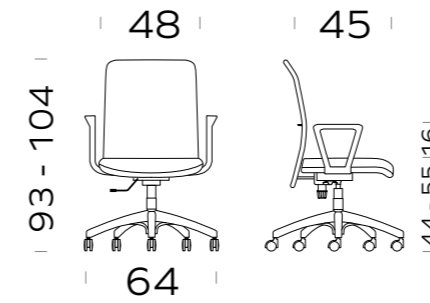

SCHIENALE IN RETE, SUPPORTO LOMBARE REGOLABILE  
 MESH BACKREST, ADJUSTABLE LUMBAR SUPPORT  
 DOSSIER EN RÉVILLE, SOUTIEN LOMBAIRE RÉGLABLE  
 NETZ RÜCKENLEHNE, VERSTELLBARE LUMBALSTÜTZE  
 RESPALDO EN MALLA, SUPORTE LUMBAR REGLABLE

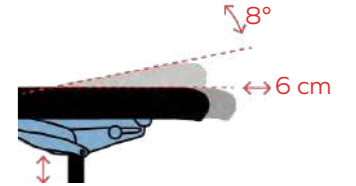

Mechanism: **SynchroPlus**  
 Slide



Blocco oscillante, Regolazione altezza/tensione dello schienale, Regolazione in profondità del sedile  
 (Un-)locking device, Backrest height/tension adjustment, Depth adjustment of the seat  
 Système de blocage-déblocage de l'oscillation, Réglage en hauteur/ d'intensité du dossier,  
 Réglage en profondeur de l'assise  
 Blockierung der Rückenlehne / Spannungsregler / Höhenverstellbar, Sitztiefenverstellung  
 Sistema de bloqueo-desbloqueo del respaldo, Ajuste de altura/tensión, Ajuste de profundidad del asiento

| BASE<br>BASE<br>PIETEMENT<br>GESTELL<br>BASE   | RUOTA/PIEDINO<br>CASTOR/FEET<br>ROULETTES/PATINS<br>ROLLEN/GLEITER<br>RUEDAS/PIES  | STRUTTURA<br>STRUCTURE<br>STRUCTURE<br>STRUKTUR<br>ESTRUCTURA   | CODICE<br>CODE<br>CODE<br>ARTIKEL<br>CÓDIGO | KG    | RETE<br>MESH<br>RESILLE<br>NETZ<br>MALLA | TESSUTI/FINITURE<br>UPHOLSTERIES/FINISHING<br>REVETEMENTS<br>STOFFGRUPPE<br>TAPICERÍAS |     |     |     |
|--|--|---|---|-------|--|--|-----|-----|-----|
|  |  |   |   |       |  | D  | E   | F   | G   |
| <br><br>5 razze poliammide<br>5-spoke polyamide<br>5-branches polyamide<br>5-Stern Polyamid Fußkreuz<br>estrella en polyamida |  *<br><br>d.50mm autofrenanti gommata<br>soft self-braking d.50mm<br>d.50 mm gommées autofreinante<br>weiche gebremste D.50 mm<br>ruedas goma diam.50 autofreno |  *<br><br>RAL 9005 | <b>OT0230</b>                               | 12,20 | M-N                                      | 420  | 426 | 432 | 471 |

\* DISPONIBILE ANCHE IN  
 ALSO AVAILABLE  
 ÉGALEMENT DISPONIBLE EN  
 ERHÄLTlich AUCh IN  
 TAMBIÉN DISPONIBLE EN



RAL 9016



RAL 1012



RAL 3012









RAL 6021



RAL 7032



RAL 7046

| OPZIONE<br>OPTIONALS<br>OPTIONS<br>OPTIONEN<br>OPCIONES                               | VARIANTE<br>VARIANT<br>VARIANTE<br>VARIANTE<br>VARIANTE                             | CODICE<br>CODE<br>CODE<br>ARTIKEL<br>CÓDIGO | KG   | PREZZO<br>PRICE<br>PRIX<br>PREIS<br>PRECIO |
|---|---|---|------|--|
| *    | Bracciolo fisso<br>Fixed armrest<br>Accoudoir fixe<br>feste Armlehne<br>Brazos fijo | <b>XB070</b>                                | 0,60 | 24   |
| *    | <b>2D</b>   | <b>XB020</b>                                | 1,30 | 39   |
| *    | <b>2D SOFT</b>  | <b>XB022</b>                                | 1,60 | 61   |
| *    | <b>3D</b>   | <b>XB021</b>                                | 1,30 | 71   |
| *  | <b>3D SOFT</b>  | <b>XB023</b>                                | 1,60 | 92   |
| *  | <b>4D EXTRASOFT</b>   | <b>XB089</b>                                | 2,60 | 102  |
|    | <b>4D EXTRASOFT</b>   | <b>XB090</b>                                | 2,60 | 161  |

\* DISPONIBILE ANCHE IN  
ALSO AVAILABLE  
ÉGALEMENT DISPONIBLE EN  
ERHÄLTlich AUCH IN  
TAMBIÉN DISPONIBLE EN



RAL 9016



RAL 1012



RAL 3012









RAL 6021



RAL 7032



RAL 7046

| OPZIONE<br>OPTIONALS<br>OPTIONS<br>OPTIONEN<br>OPCIONES                               | VARIANTE<br>VARIANT<br>VARIANTE<br>VARIANTE<br>VARIANTE  | CODICE<br>CODE<br>CODE<br>ARTIKEL<br>CÓDIGO | KG   | PREZZO<br>PRICE<br>PRIX<br>PREIS<br>PRECIO | TESSUTI/FINITURE<br>UPHOLSTERIES/FINISHING<br>REVETEMENTS<br>STOFFGRUPPE<br>TAPICERIAS |    |    |    |
|---|--|---|------|--|--|----|----|----|
|   |  |   |      |  | D  | E  | F  | G  |
|    | Poggiatesta<br>Headrest<br>Appui-tête<br>Kopfstütze<br>Reposacabezas<br><br>ONLY FOR <b>OT0127</b><br><b>OT0346</b>  | <b>XT008</b>                                | 0,80 |  | 53   | 60 | 65 | 99 |
|    | Copriedile removibile<br>Removable seat cover<br>Housse assise, amovible<br>Sitzbezug, abnehmbar<br>Funda para asiento retirable<br><br><b>SynchroPlus</b> | <b>FOD144</b>                               |      |  | 36   | 40 | 48 |    |
|    | Copriedile removibile<br>Removable seat cover<br>Housse assise, amovible<br>Sitzbezug, abnehmbar<br>Funda para asiento retirable<br><br><b>MiniSynchro</b> | <b>FOD151</b>                               |      |  | 36   | 40 | 48 |    |
|   | Sedile Comfort<br>Comfort Seats<br>Assise Comfort<br>Komfort Sitz<br>Asiento Comfortable   | <b>XD017</b>                                | 0,90 | 20   |  |    |    |    |
|  | Molle sedile<br>Seat springs<br>Ressorts assise<br>Sitz Federkern<br>Resortes asientos<br><br>ONLY FOR <b>SynchroPlus</b>                                  | <b>XD006</b>                                | 0,80 | 37   |  |    |    |    |
|  | SEAT WITH<br>NEGATIVE<br>INCLINATION<br><br>ONLY FOR <b>SynchroPlus</b>  | <b>XM007</b>                                | 1,30 | 35   |  |    |    |    |

\* DISPONIBILE ANCHE CON  
ALSO AVAILABLE WITH  
ÉGALEMENT DISPONIBLE AVEC  
ERHÄLTlich AUCH MIT  
TAMBIÉN DISPONIBLE CON



d.50 mm autofrenanti  
self-braking d.50mm  
d.50mm autofreinante  
gebremste D.50mm  
diam.50 autofreno

**SAME PRICE**

# SLIM Task

idea: *Pietro Lovato*



## TECHNICAL INFORMATION

### 1. STRUTTURA:

Monoscocca in tecnopolimero, finitura RAL o imbottita con spugna e rivestita, con struttura di sostegno in tubo tondo d'acciaio, Ø16mm, con o senza bracciali, finitura cromata (15µm) o verniciata a polveri

### 2. MECCANISMO:

Comando elevazione a gas, finitura nera

### 3. BASE:

- Base 5 razze in alluminio, Ø 670mm, finitura lucida
- Base 5 razze in poliamide con carica di fibra di vetro, Ø640mm, finitura nero

### 4. RUOTE/PIEDINI:

- Ruote Ø 50mm, autofrenanti o autofrenanti e gommate, finitura nera
- Piedini in poliamide, h. 61mm, finitura nera

### 5. BRACCIOLI:

Bracciolo triangolare in tondo d'acciaio, Ø 12mm, finitura cromata (15µm) o verniciata a polveri (imbottito e rivestito)

### 1. STRUCTURE:

Engineering polymer monocoque, ral finish or foam padded and upholstered. Round steel bar structure Ø16mm, with or without armrests, chromed finish (15µm) or powder coated

### 2. MECHANISM:

Height adjustable, Black finish

### 3. BASE:

- Polished aluminium 5 spoke base, Ø670 mm
- Fiberglass reinforced polyamide 5 spoke base, Ø640 mm, black finish

### 4. CASTORS/FEET:

- Ø 50 mm self-braking castors, or soft self-bracking, Black finish
- h. 61 mm polyamide glides, black finish

### 5. ARMREST:

Steel round bar Ø12 mm, triangular armrest, chromed finish (15µm) or powder coated. Padded and upholstered

### 1. STRUCTURE:

Monocoque en polymère technique, finition RAL ou rembourrée de mousse et tapissée. Structure de support en tube d'acier, Ø16mm, avec ou sans accoudoirs, finition chromé (15µm) o verni époxy

### 2. MECANISME:

Réglable en hauteur, finition noir

### 3. PIÈTEMENT:

- Piètement 5 branches alu poli, Ø 670mm
- Piètement 5 branches en polyamide renforcé en fibre de verre, Ø640mm, finition noir

### 4. ROULETTES/PATINS:

- Roulettes Ø 50mm, autofreinantes ou autofreinantes et gommées, finition chromé ou noir
- Patins en polyamide, h. 61mm, finition noir

### 5. ACCOUDOIR:

Accoudoir triangulaire en tige d'acier, Ø 12mm, finition chromé (15µm) ou verni époxy (manchette rembourrée et tapissée)

### 1. STRUKTUR:

Technopolymer Schale, RAL Farben oder ausgepolstert mit Schaumstoff und Bezug, Rund-Stahlrohrgestell Ø 16 mm, mit oder ohne Armlehnen, verchromt (15µm) oder pulverbeschichtet

### 2. MECHANIK:

Sitzhöhenverstellung, drehbar, verchromt

### 3. GESTELL:

- 5-Stern Alu poliertes Fußkreuz, Ø 670 mm
- 5-Stern schwarzes glasfaserverstärktes Polyamid Fußkreuz, Ø640 mm

### 4. ROLLEN/GLEITER:

- Ø 50 mm gebremste, oder weiche gebremste Rollen, schwarz oder verchromt
- Polyamidgleiter, H. 61 mm, schwarz

### 5. ARMLEHNE:

Feste dreieckige Armlehne aus Stahlstab, Ø 12 mm, verchromt (15µm) oder pulverbeschichtet, ausgepolstert mit Bezug

### 1. ESTRUCTURA:

Monocasco de tecnopolimero, acabado RAL o acolchado con espuma y recubierto en tejido, con estructura de soporte en tubo de acero redondo, Ø16mm, con o sin brazos, acabado cromado (15µm) o con recubrimiento en polvo

### 2. MECANISMO:

Control de elevación de gas, acabado negro

### 3. BASE:

- Base de 5 estrellas en aluminio, Ø 670mm, acabado brillante
- Base de 5 radios en poliamida con carga de fibra de vidrio, Ø640mm, acabado negro

### 4. RUEDAS / PIES:

- Ruedas de Ø 50 mm, autofrenado o autofrenado y blandas, acabado negro
- Pies en poliamida, h. 61mm, acabado negro

### 5. BRAZOS:

Brazos triangular de acero redondo, Ø 12 mm, acabado cromado (15µm) o con recubrimiento en polvo (acolchado y tapizado)



ID 1111209613

# SLIM Task

GIREVOLE, SCOCCA IN TECNOPOLIMERO  
 SWIVEL, ENGINEERING POLIMER SHELL  
 PIVOTANT, COQUE EN POLYMÈRE TECHNIQUE  
 DREHBAR, TECHNOPOLYMER SCHALE  
 GIRATORIA, CONCHA EN TECNOPOLÍMERO

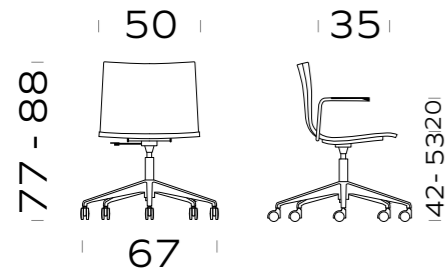

Mechanism: **SeatPlate** ↑↓

Regolazione altezza  
 Height adjustment  
 Réglage en hauteur  
 Höhenverstellung  
 Ajuste de altura



| BASE<br>BASE<br>PIETEMENT<br>GESTELL<br>BASE | RUOTA/PIEDINO<br>CASTOR/FEET<br>ROULETTES/PATINS<br>ROLLEN/GLEITER<br>RUEDAS/PIES | STRUTTURA<br>STRUCTURE<br>STRUCTURE<br>STRUKTUR<br>ESTRUCTURA | VARIANTE<br>VARIANT<br>VARIANTE<br>VARIANTE<br>VARIANTE                             | CODICE<br>CODE<br>CODE<br>ARTIKEL<br>CÓDIGO | KG   | PREZZO<br>PRICE<br>PRIX<br>PREIS<br>PRECIO |
|--|---|---|---|---|------|--|
|  |   |   |   |   |      | SHELL RAL                                  |
|  |   |   | con braccioli<br>with arms<br>avec accoudories<br>mit Armlehnen<br>con brazos       | SL0334                                      | 8,90 | 242  |
|  |   |   | senza braccioli<br>without arms<br>sans accoudories<br>ohne Armlehnen<br>sin brazos | SL0323                                      | 7,80 | 218  |
|  |   |   | con braccioli<br>with arms<br>avec accoudories<br>mit Armlehnen<br>con brazos       | SL0074                                      | 9,00 | 350  |
|  |   |   | senza braccioli<br>without arms<br>sans accoudories<br>ohne Armlehnen<br>sin brazos | SL0045                                      | 7,90 | 320  |

### STRUCTURE RAL

\* DISPONIBILE ANCHE IN  
 ALSO AVAILABLE  
 ÉGALEMENT DISPONIBLE EN  
 ERHÄLTICH AUCH IN  
 TAMBIÉN DISPONIBLE EN

|          |          |          |
|----------|----------|----------|
|          |          |          |
| RAL 9016 | RAL 1012 | RAL 3012 |
|          |          |          |
| RAL 6021 | RAL 7032 | RAL 7046 |

### SHELL RAL

|          |          |          |          |          |
|----------|----------|----------|----------|----------|
|          |          |          |          |          |
| RAL 9016 | RAL 1012 | RAL 3012 | RAL 3001 | RAL 6021 |
|          |          |          |          |          |
| RAL 7032 | RAL 5009 | RAL 7046 | RAL 9005 | RAL 9016 |

\* DISPONIBILE ANCHE CON  
 ALSO AVAIBLE WITH  
 ÉGALEMENT DISPONIBLE AVEC  
 ERHÄLTICH AUCH MIT  
 TAMBIÉN DISPONIBLE CON

d.50 mm autofrenanti  
 self-braking d.50mm  
 d.50mm autofreinante  
 gebremste D.50mm  
 diam.50 autofreno

**SAME PRICE**

# SLIM Task Stool

GIREVOLE, SCOCCA IN TECNOPOLIMERO  
 SWIVEL, ENGINEERING POLIMER SHELL  
 PIVOTANT, COQUE EN POLYMÈRE TECHNIQUE  
 DREHBAR, TECHNOPOLYMER SCHALE  
 GIRATORIA, CONCHA EN TECNOPOLÍMERO

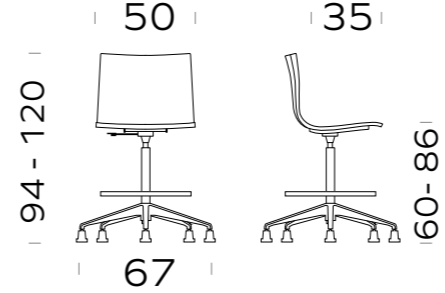

Mechanism: **SeatPlate** ↑↓

Regolazione altezza  
 Height adjustment  
 Réglage en hauteur  
 Höhenverstellung  
 Ajuste de altura













| BASE<br>BASE<br>PIETEMENT<br>GESTELL<br>BASE | RUOTA/PIEDINO<br>CASTOR/FEET<br>ROULETTES/PATINS<br>ROLLEN/GLEITER<br>RUEDAS/PIES | STRUTTURA<br>STRUCTURE<br>STRUCTURE<br>STRUKTUR<br>ESTRUCTURA | VARIANTE<br>VARIANT<br>VARIANTE<br>VARIANTE<br>VARIANTE                             | CODICE<br>CODE<br>CODE<br>ARTIKEL<br>CÓDIGO | KG   | PREZZO<br>PRICE<br>PRIX<br>PREIS<br>PRECIO |
|--|---|---|---|---|------|--|
|  |   |   |   |   |      | SHELL RAL                                  |
|  |   |   | con braccioli<br>with arms<br>avec accoudories<br>mit Armlehnen<br>con brazos       | SL0081                                      | 9,50 | 367  |
|  |   |   | senza braccioli<br>without arms<br>sans accoudories<br>ohne Armlehnen<br>sin brazos | SL0052                                      | 8,50 | 338  |

| OPZIONE<br>OPTIONALS<br>OPTIONS<br>OPTIONEN<br>OPCIONES | VARIANTE<br>VARIANT<br>VARIANTE<br>VARIANTE<br>VARIANTE  | CODICE<br>CODE<br>CODE<br>ARTIKEL<br>CÓDIGO | KG   | PREZZO<br>PRICE<br>PRIX<br>PREIS<br>PRECIO |
|---|--|---|------|--|
|   | Anello poggipiedi in alluminio<br>Aluminium footrest ring<br>Appui-pieds circulaire en aluminium<br>Ringfußstütze aus Aluminium<br>Reposapiés anello en aluminio | XP004                                       | 1,20 | 106  |

### SHELL RAL

|          |          |          |          |          |
|----------|----------|----------|----------|----------|
|          |          |          |          |          |
| RAL 9016 | RAL 1012 | RAL 3012 | RAL 3001 | RAL 6021 |
|          |          |          |          |          |
| RAL 7032 | RAL 5009 | RAL 7046 | RAL 9005 | RAL 9016 |

# SLIM Task **OPTIONALS**

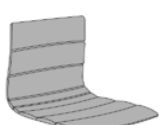
| OPZIONE<br>OPTIONALS<br>OPTIONS<br>OPTIONEN<br>OPCIONES                             | VARIANTE<br>VARIANT<br>VARIANTE<br>VARIANTE<br>VARIANTE  | CODICE<br>CODE<br>CODE<br>ARTIKEL<br>CÓDIGO | KG   | PREZZO<br>PRICE<br>PRIX<br>PREIS<br>PRECIO | TESSUTI/FINITURE<br>UPHOLSTERIES/FINISHING<br>REVETEMENTS<br>STOFFGRUPPE<br>TAPICERIAS |     |     |     |     |
|---|--|---|------|--|--|-----|-----|-----|-----|
|   |  |   |      |  | D  | E   | F   | G   | H   |
|    | <br>Chromed   | <b>XB030</b>                                | 2,30 | 84   |  |     |     |     |     |
|   | * <br>RAL 9005                                      | <b>XB035</b>                                | 2,30 | 82   |  |     |     |     |     |
|    | <br>Chromed   | <b>XB040</b>                                | 2,30 |  | 112  | 112 | 112 | 112 | 112 |
|   | * <br>RAL 9005                                      | <b>XB042</b>                                | 2,30 |  | 110  | 110 | 110 | 110 | 110 |
|    | <b>SHELL<br/>FIREPROOF</b><br>ONLY FOR <br>RAL 9016 | <b>XI018</b>                                | 2,20 | 46   |  |     |     |     |     |
|   | <b>SEAT CUSHION</b>  | <b>XC017</b>                                | 0,80 |  | 39   | 44  | 50  | 53  | 62  |
|  | <b>UPHOLSTERED</b>   | <b>XA022</b>                                | 0,50 |  | 97   | 102 | 120 | 172 | 198 |
|  | <b>UPHOLSTERED</b>   | <b>XA014</b>                                | 0,50 |  | 97   | 102 | 120 | 172 | 198 |

\* DISPONIBILE ANCHE IN  
ALSO AVAILABLE  
ÉGALEMENT DISPONIBLE EN  
ERHÄLTlich AUCh IN  
TAMBIÉN DISPONIBLE EN



RAL 9016



RAL 1012



RAL 3012



RAL 6021



RAL 7032



RAL 7046

 MOVING

|                  | ALIA C | ALIA TOP | ALIA K | ALIA LOUNGE | ARTURO | ATTIVA | AURELIA | BOHEME | CARDINALE | CARMEN | CRONO | CRONO 24 | CUBIX | DAFNE | DAMA | DAMA R | DRESSCHAIR | DRESSCHAIR R | ECOCHAIR | ELETTA | FLEXA | FORMA | GIADA | GIUNONE | HOOP | IRIS | ISY | MOVING73 TASK | MOVING73 TASK STOOL | OTAVO Q | OTAVO R | PILATUS | R&G | SLIM | TOSCA | VIVA | ZIP |  |  |  |  |
|------------------|--------|----------|--------|-------------|--------|--------|---------|--------|-----------|--------|-------|----------|-------|-------|------|--------|------------|--------------|----------|--------|-------|-------|-------|---------|------|------|-----|---------------|---------------------|---------|---------|---------|-----|------|-------|------|-----|--|--|--|--|
| D TARGET         |        |          |        |             |        |        |         |        |           |        |       |          |       |       |      |        |            |              |          |        |       |       |       |         |      |      |     |               |                     |         |         |         |     |      |       |      |     |  |  |  |  |
| D EXPO           |        |          |        |             |        |        |         |        |           |        |       |          |       |       |      |        |            |              |          |        |       |       |       |         |      |      |     |               |                     |         |         |         |     |      |       |      |     |  |  |  |  |
| D KING           |        |          |        |             |        |        |         |        |           |        |       |          |       |       |      |        |            |              |          |        |       |       |       |         |      |      |     |               |                     |         |         |         |     |      |       |      |     |  |  |  |  |
| D RADIO          |        |          |        |             |        |        |         |        |           |        |       |          |       |       |      |        |            |              |          |        |       |       |       |         |      |      |     |               |                     |         |         |         |     |      |       |      |     |  |  |  |  |
| D SILVIA         |        |          |        |             |        |        |         |        |           |        |       |          |       |       |      |        |            |              |          |        |       |       |       |         |      |      |     |               |                     |         |         |         |     |      |       |      |     |  |  |  |  |
| E ROCCIA         |        |          |        |             |        |        |         |        |           |        |       |          |       |       |      |        |            |              |          |        |       |       |       |         |      |      |     |               |                     |         |         |         |     |      |       |      |     |  |  |  |  |
| E ONE            |        |          |        |             |        |        |         |        |           |        |       |          |       |       |      |        |            |              |          |        |       |       |       |         |      |      |     |               |                     |         |         |         |     |      |       |      |     |  |  |  |  |
| E CONVERT        |        |          |        |             |        |        |         |        |           |        |       |          |       |       |      |        |            |              |          |        |       |       |       |         |      |      |     |               |                     |         |         |         |     |      |       |      |     |  |  |  |  |
| E DEMETRA        |        |          |        |             |        |        |         |        |           |        |       |          |       |       |      |        |            |              |          |        |       |       |       |         |      |      |     |               |                     |         |         |         |     |      |       |      |     |  |  |  |  |
| E JEWEL          |        |          |        |             |        |        |         |        |           |        |       |          |       |       |      |        |            |              |          |        |       |       |       |         |      |      |     |               |                     |         |         |         |     |      |       |      |     |  |  |  |  |
| F MINI MELANGE   |        |          |        |             |        |        |         |        |           |        |       |          |       |       |      |        |            |              |          |        |       |       |       |         |      |      |     |               |                     |         |         |         |     |      |       |      |     |  |  |  |  |
| F PLATINUM       |        |          |        |             |        |        |         |        |           |        |       |          |       |       |      |        |            |              |          |        |       |       |       |         |      |      |     |               |                     |         |         |         |     |      |       |      |     |  |  |  |  |
| F XTREME         |        |          |        |             |        |        |         |        |           |        |       |          |       |       |      |        |            |              |          |        |       |       |       |         |      |      |     |               |                     |         |         |         |     |      |       |      |     |  |  |  |  |
| G CYCLE          |        |          |        |             |        |        |         |        |           |        |       |          |       |       |      |        |            |              |          |        |       |       |       |         |      |      |     |               |                     |         |         |         |     |      |       |      |     |  |  |  |  |
| G LEATHER        |        |          |        |             |        |        |         |        |           |        |       |          |       |       |      |        |            |              |          |        |       |       |       |         |      |      |     |               |                     |         |         |         |     |      |       |      |     |  |  |  |  |
| G LANE E MELANGE |        |          |        |             |        |        |         |        |           |        |       |          |       |       |      |        |            |              |          |        |       |       |       |         |      |      |     |               |                     |         |         |         |     |      |       |      |     |  |  |  |  |
| H COLUMBIA       |        |          |        |             |        |        |         |        |           |        |       |          |       |       |      |        |            |              |          |        |       |       |       |         |      |      |     |               |                     |         |         |         |     |      |       |      |     |  |  |  |  |
| L LINE           |        |          |        |             |        |        |         |        |           |        |       |          |       |       |      |        |            |              |          |        |       |       |       |         |      |      |     |               |                     |         |         |         |     |      |       |      |     |  |  |  |  |
| M RETE ATTIVA    |        |          |        |             |        |        |         |        |           |        |       |          |       |       |      |        |            |              |          |        |       |       |       |         |      |      |     |               |                     |         |         |         |     |      |       |      |     |  |  |  |  |
| M SPIDER         |        |          |        |             |        |        |         |        |           |        |       |          |       |       |      |        |            |              |          |        |       |       |       |         |      |      |     |               |                     |         |         |         |     |      |       |      |     |  |  |  |  |
| N MICRO          |        |          |        |             |        |        |         |        |           |        |       |          |       |       |      |        |            |              |          |        |       |       |       |         |      |      |     |               |                     |         |         |         |     |      |       |      |     |  |  |  |  |
| N TARGET         |        |          |        |             |        |        |         |        |           |        |       |          |       |       |      |        |            |              |          |        |       |       |       |         |      |      |     |               |                     |         |         |         |     |      |       |      |     |  |  |  |  |



Tabella sinottica dei rivestimenti, sedia per sedia  
 Synoptic table of coverings, chair by chair  
 Tableau synoptique des revêtements chaise par chaise  
 Übersichtstabelle passende Auspolsterungen je Stuhlserie  
 Tabla sinóptica de revestimientos, silla por silla



Dal 1980 MOVING progetta e realizza sedie ergonomiche di alta qualità nel suo stabilimento di Trissino, Vicenza. La tradizione artigianale e l'approccio innovativo caratterizzano ogni prodotto che l'azienda propone per l'ufficio, la casa e gli spazi comuni, perchè il benessere delle persone incontra la funzionalità e l'estetica.

*Since 1980 MOVING has designed and manufactured high quality seats at their facilities in Trissino, in the Northeast Italy. Traditional craftsmanship and an innovation-driven approach characterise the brand's products, a wide range of solutions for office spaces, home and public spaces, so that wellbeing meets functionality and aesthetics.*

*Depuis 1980, MOVING conçoit et fabrique des sièges de haute qualité dans l'usine de Trissino, dans le nord-est de l'Italie. L'artisanat traditionnel et une approche axée sur l'innovation caractérisent les produits de la marque, comprenant une large gamme de solutions pour les espaces de bureau, la maison et les espaces publics, afin que le bien-être rencontre la fonctionnalité et l'esthétique.*

*Seit 1980 entwickelt und produziert Moving in seinem Werk in Trissino, Vicenza, hochwertige, ergonomische Stühle. Die handwerkliche Tradition und der innovative Ansatz, kennzeichnen jedes Produkt das das Unternehmen für Büro, Wohnbereich und Gemeinschaftsräume anbietet, damit das Wohlbefinden des Benutzers Funktionalität und Ästhetik trifft.*

*Desde 1980, Moving diseña y produce sillas ergonómicas de alta calidad en su planta de Trissino, Vicenza. La tradición artesanal y el enfoque innovador caracterizan todos los productos que la empresa ofrece para la oficina, el hogar y otros entornos donde el bienestar de las personas se encuentra con la funcionalidad y la estética.*

[movingchairs.it](http://movingchairs.it)

MOVING srl  
Via dell'Artigianato 1  
Trissino (VI) Italy  
T +39 0445 490777  
[italia@moving.vi.it](mailto:italia@moving.vi.it)  
[export@moving.vi.it](mailto:export@moving.vi.it)

[movingchairs.it](http://movingchairs.it)